

CLOSURE PLAN

PLANT BOWEN ASH POND 1 (AP-1) CLOSURE

BARTOW COUNTY, GEORGIA

FOR



Georgia
Power

JULY 2021



Geosyntec 
consultants

TABLE OF CONTENTS

1.	INTRODUCTION	1
2.	GENERAL	1
3.	NOTIFICATION	1
4.	SURVEY CONTROL	1
5.	WRITTEN CLOSURE PLAN	1
5.1	OVERVIEW	1
5.2	CLOSURE STEPS	3
5.3	CLOSURE PHASES	4
5.4	PROCEDURES DURING CLOSURE.....	7
5.4.1	Dewatering and Stabilization.....	7
5.4.2	Liquids Management	7
5.4.3	Excavation of CCR	8
5.4.4	CCR Removal Verification Protocol.....	8
5.4.5	CCR Placement and Compaction	9
5.4.6	Stormwater and Contact-Water Management	10
5.4.7	Leachate Management.....	11
5.4.8	Fugitive Dust Control Plan	12
5.4.9	Equipment Decontamination	13
5.4.10	Inspections.....	13
5.5	CLOSURE DESIGN FEATURES.....	14
5.5.1	Lined Area Subgrade (Foundation).....	14
5.5.2	Composite Liner.....	15
5.5.3	Leachate Collection and Removal System (LCRS).....	16
5.5.4	Final Cover System.....	16
5.5.5	Stormwater Management System.....	17
5.6	ACHIEVEMENT OF CLOSURE PERFORMANCE STANDARDS	18
5.7	MAXIMUM INVENTORY OF CCR.....	19
5.8.	LARGEST AREA REQUIRING FINAL COVER.....	19
5.9	SCHEDULE FOR COMPLETING ACTIVITIES	20
6.	DRAINAGE AND STABILIZATION.....	20

7. CERTIFICATION OF CLOSURE..... 20

8. DIRECTIONAL INFORMATIONAL SIGNS 20

9. REMOVAL OF CCR FOR BENEFICIAL USE OR LANDFILL DISPOSAL..... 21

 9.1 REMOVAL OF CCR FOR BENEFICIAL USE 21

 9.2 REMOVAL OF CCR FOR LANDFILL DISPOSAL 21

10. VEGETATIVE PLAN..... 22

11. SITE EQUIPMENT NEEDED 23

12. SEDIMENT REMOVAL..... 23

13. EROSION AND SEDIMENT CONTROL..... 23

14. COST OF CLOSURE AND FINANCIAL ASSURANCE..... 23

15. CLOSURE SCHEDULE..... 23

16. RECORDKEEPING/NOTIFICATION/INTERNET REQUIREMENTS 24

17. LEGAL DESCRIPTION..... 24

LIST OF TABLES

Table 1 Closure Cost Estimate

LIST OF APPENDICES

Appendix A Foundation Improvement Plan

LIST OF ACRONYMS

CCL	Compacted Clay Liner
CCR	Coal Combustion Residuals
CFR	Code of Federal Regulations
CQA	Construction Quality Assurance
FGD	Flue Gas Desulfurization
GA EPD	Georgia Environmental Protection Division
GCL	Geosynthetic Clay Liner
GPC	Georgia Power Company
GWSCC	Georgia Water Soil Conservation Commission
HDPE	High Density Polyethylene
LCRS	Leachate Collection and Removal System
LLDPE	Linear-Low Density Polyethylene
NOI	Notice of Intent
NPDES	National Pollutant Discharge Elimination System
O&M	Operations and Maintenance
P.E.	Professional Engineer
WWTS	Wastewater Treatment System

1. INTRODUCTION

This Closure Plan is included as part of the permit application package being submitted to the Georgia Environmental Protection Division (GA EPD) to close ash pond AP-1, an existing coal combustion residuals (CCR) surface impoundment at Plant Bowen, located in Bartow County near Cartersville, Georgia. This Closure Plan has been prepared for Georgia Power Company (GPC) pursuant to the Federal CCR Rule in Title 40 of the Code of Federal Regulations (CFR) §257 (40 CFR §257) and the State CCR Rule in Chapter 391-3-4-.10 of the Georgia Rules for Solid Waste Management, Coal Combustion Residuals.

2. GENERAL

GPC will close AP-1 in a manner that minimizes the need for further maintenance and the potential of post-closure releases of contaminants to groundwater or surface waters. The written closure plan presented subsequently in this document and the Closure Drawings included in Section 9 of Part A of the permit application present the closure design and provide guidance on the sequence of closure. These documents are supplemented by engineering analyses and calculations contained in the Engineering Report in Section 3 of Part B of the permit application.

3. NOTIFICATION

For the reasons described in Section 1 of Part A of this permit application, GPC will follow the alternative closure procedures specified in 40 CFR §257.103 based on documentation and certification by GPC that no alternative CCR disposal capacity is available on-site or off-site for flue gas desulfurization (FGD) waste streams. As required by 40 CFR §257.103(a)(2), once alternative capacity is available, AP-1 will cease receiving CCR and submit a Notice of Intent (NOI) to Close in accordance with the timeframes in 40 CFR §257.102(e) and (f).

4. SURVEY CONTROL

A survey of the permit boundary is provided in the Closure Drawings. Areas of CCR removal will be located to the best of GPC's ability during closure activities and will be surveyed by a Registered Surveyor. Upon completion of closure, the actual final limit of CCR will be confirmed and a Registered Surveyor will provide a legal description of the CCR management boundary as part of closure certification.

5. WRITTEN CLOSURE PLAN

5.1 OVERVIEW

Pursuant to State CCR Rule 391-3-4-.10(7)(c), the ash pond will be closed in accordance with this Closure Plan. An Initial Written Closure Plan was posted to the facility's operating record on October 17, 2016 and was posted to the GPC CCR Compliance website 30 days later. The written closure plan was amended and re-posted to the

facility's operating record on September 27, 2018 and to the GPC CCR Compliance website 30 days later. This Closure Plan supersedes that plan and may be amended by GPC at any time. Moreover, as required by 40 CFR §257.102(b)(3)(ii), this plan must be amended whenever: (i) there is a change in the operation of the CCR unit that would substantially affect the plan; or (ii) before or after closure activities have commenced, unanticipated events necessitate a revision of the plan. The timeframes for any amendment to the plan will be in accordance with those specified in 40 CFR §257.102(b)(3)(iii).

AP-1 will be closed in phases, with each phase consisting of a specific set of closure construction activities. An overview of the closure approach is provided below. More detailed descriptions of the phased sequencing of closure and associated procedures are provided subsequently.

- The CCR in AP-1 will be excavated to remove all visible CCR to the extent practicable plus a minimum 6-inches of additional soil. Additional excavation of residuum will occur as necessary to satisfy the foundation improvement requirements of the closure design. CCR removal and residuum excavation criteria are discussed subsequently in this Closure Plan. Once excavation is complete within the area to be consolidated and lined, compacted fill will be placed to improve the foundation as well as to achieve the specified liner system subgrades. Areas of AP-1 outside the limits of the consolidated lined area will be graded to drain after CCR is removed.
- A composite liner and an overlying leachate collection and removal system (LCRS) (together referred to as the liner system) will be installed on the subgrade across the entire consolidated lined area.
- Once the liner system is installed, the consolidated lined area will be filled with appropriately dewatered and compacted AP-1 CCR.
- A final cover system will be installed over the filled consolidated lined area. The final cover system will consist of either a soil-geosynthetic composite cover system or a ClosureTurf® (i.e., synthetic engineered turf) cover system. If a soil and geosynthetic cover system is used, the cover will be vegetated with native grass species and other suitable grasses to provide erosion protection, establish a diverse grassland habitat, and provide attractive aesthetics. If ClosureTurf® is used, a synthetic engineered turf material will be placed as the upper layer of the final cover system to provide erosion protection and an appearance similar to native vegetation.
- The final cover system will be graded to a general dome-shaped configuration to promote stormwater runoff, with a central ridgeline, a 4 percent (minimum) top-deck that slopes towards 3 horizontal to 1 vertical (3H:1V) sideslopes (between drainage benches), that in turn slope to a perimeter channel. Both final cover system options would virtually eliminate infiltration of surface water into the closed CCR unit while promoting stormwater runoff away from the consolidated lined area.

- When completed, the approximately 144-acre consolidated, lined, and covered final limit of CCR will occupy approximately 57 percent of the current AP-1 area.

These closure activities and features are further described in the remainder of this Closure Plan. The closure design and sequence is illustrated on the Closure Drawings in Section 9 of Part A of the permit application.

5.2 CLOSURE STEPS

Implementation of AP-1 closure construction will be completed in steps, consisting of the following general sequence of activities:

- Removing free water contained in AP-1 and decommissioning the ponds currently within AP-1;
- Dewatering the CCR as practicable using dewatering wells, vacuum well points, trench drains, windrowing, geotextile tubes, or a combination of measures;
- Managing all removed contact water using temporary pumping systems that will route the water to temporary lined storage ponds; and conveying these waters for treatment at a temporary on-site wastewater treatment system (WWTS);
- Stripping cover soil and topsoil presently covering the north stack area and stockpiling it for future reuse;
- Constructing a new section of perimeter dike to contain the southern end of the consolidated area;
- Excavating AP-1 CCR material down to the native ground (residuum soil layer) that underlies the impoundment, plus a minimum of 6 inches of residuum;
- Conducting foundation improvements in all areas of the to-be-lined consolidated area; generally, the foundation improvement program will involve over-excavation of residuum foundation soils to specified depths, proof-rolling of the excavated foundation, localized treatment of any observed soft areas in the foundation bottom, and backfilling to grade with compacted fill;
- Removing any recoverable CCR observed in the residuum at the bottom of the over-excavated residuum foundation soils across the entire AP-1 footprint;
- Final grading and contouring of the backfill to prepare the subgrade for installation of the liner system throughout the consolidated lined area;
- Installing a composite liner and LCRS in each disposal cell and a leachate pumping, storage, and piping system (i.e., leachate transmission system) routed to a temporary on-site WWTS;

- Constructing a new section of perimeter dike to contain the northern end of the consolidated area;
- Placing excavated CCR in the consolidated lined area;
- Installing final cover and stormwater management systems over the consolidated lined area once CCR filling is complete and final grades are achieved;
- Grading and contouring the other areas beyond the consolidated lined area (i.e., AP-1 areas primarily to the north and south of the limits of the consolidated lined areas), and constructing final closure stormwater management systems; and
- Conducting post-closure care monitoring and maintenance for 30 years.

Note that many of the activities described above will be conducted in a phased and overlapping manner. The phasing of activities would progress from south to north as discussed below.

5.3 CLOSURE PHASES

Closure of AP-1 will occur in a phased manner. A conceptual phasing approach with nine phases (eight numbered development phases, with the ninth phase being final closure) has been developed. Information on the phase limits, sequencing, and details is presented on the Closure Drawings. The sequencing of the phases and phase activities are summarized below. During closure, the number of phases and the phase boundaries may be adjusted based on factors such as rate of construction, availability of disposal capacity, seasonal considerations, and optimization of stormwater and contact-water management features, provided that the required design criteria and requirements set forth in the permit application package are met.

Phase 1 – Initial CCR Excavation: The initial phase of closure construction (depicted on Drawing 20 of the Closure Drawings) involves the following activities:

- Implement closure-phase procedures, controls, and plans as set forth in Section 5.4 of this Closure Plan including but not limited to fugitive dust control and stormwater and contact-water management programs;
- Remove the recycle pond and dewater CCR in the Phase 1 area located at the southern end of AP-1; dewatering will be conducted as described in Section 5.4.1 of this Closure Plan;
- Strip the cover soils from the portion of the north stack area where relocated CCR will temporarily be placed; stockpile the soils for future reuse;

- Excavate and temporarily relocate dewatered CCR from the Phase 1 area to the northern portion of AP-1 to make room for initial lined area construction (i.e., Cell 1A and 1B – collectively referred to as Cell 1);
- Conduct a foundation assessment and perform foundation improvements based on the conditions encountered throughout the Cell 1 area in accordance with the Foundation Improvement Plan in Appendix A of this Closure Plan; and
- Place and compact clean fill to grade the Cell 1 area to the required liner system subgrade elevations; the Cell 1 composite liner system will be constructed on top of this prepared subgrade during the next phase.

Phase 2 – Lining of Cell 1 and Dewatering of CCR in Future Cell 3 Area: In the second phase, the liner system for Cell 1 will be installed and CCR in the future Cell 3 area will be dewatered in preparation for relocating and consolidating the Cell 3 CCR into Cell 1 (as depicted on Drawing 20 of the Closure Drawings). Phase 2 will involve the following activities:

- Construct a new southern perimeter containment dike for the consolidated lined area;
- Construct the Cell 1 composite liner system and LCRS on top of the Phase 1 prepared subgrade;
- Undertake dewatering of CCR (as described in Section 5.4.1 of this Closure Plan) in the Cell 3 area in preparation for relocating and consolidating the CCR into lined Cell 1; and
- Continue to implement closure-phase procedures, controls, and plans as set forth in Section 5.4 of this Closure Plan, including but not limited to fugitive dust control and stormwater and contact-water management programs.

Phase 3 – Excavation and Placement of Dewatered Cell 3 CCR in Cell 1, Lining of Cell 3, and Dewatering of CCR in Future Cell 2 Area. In this third phase, the dewatered CCR in the Cell 3 area will be excavated and transported to Cell 1 for disposal. In addition, the CCR in the future Cell 2 area will be dewatered and the liner system will be installed in the Cell 3 area once CCR excavation and foundation improvement activities in that area are complete. Phase 3 is depicted on Drawing 21 of the Closure Drawings. Phase 3 will involve the following activities:

- Excavate the dewatered CCR in the Cell 3 area and transport to Cell 1 for disposal;
- Undertake dewatering of CCR (as described in Section 5.4.1 of this Closure Plan) in the Cell 2 area in preparation for relocating and consolidating the CCR into Cell 3;
- Begin Cell 1 LCRS operation in accordance with the leachate management procedures described in Section 5.4.7 of this Closure Plan;

- Once CCR removal in the Cell 3 area is complete, conduct a foundation assessment and perform foundation improvements based on the conditions encountered in the Cell 3 area, in accordance with the Foundation Improvement Plan in Appendix A of this Closure Plan;
- Place and compact clean fill to grade the Cell 3 area to the required liner system subgrade elevations; the Cell 3 composite liner system will be constructed on top of this prepared subgrade;
- Construct the Cell 3 composite liner system and LCRS on top of the prepared subgrade; and
- Continue to implement closure-phase procedures, controls, and plans as set forth in Section 5.4 of this Closure Plan, including but not limited to fugitive dust control and stormwater and contact-water management programs.

Phases 4 through 8 – Excavation and Placement of Dewatered CCR into Previously-Prepared Lined Cells, Lining of Next Cell, and Dewatering of CCR in Future Cell Area (note: this sequence is repeated for Phases 4 through 8 – i.e., until the final phase). In the fourth phase (as depicted on Drawing 21 of the Closure Drawings), the dewatered CCR in the Cell 2 area will be excavated and transported to Cells 1 and 3 for disposal. At that time, Cell 3 LCRS operation will commence. In addition, the CCR in the Cell 4 area will be dewatered, and the liner system will be installed in the Cell 2 area once CCR excavation and foundation improvement activities in that area are completed. This sequence of CCR dewatering, CCR excavation, foundation improvement, composite liner system construction, cell filling, and LCRS operation, will be followed for all subsequent phases until all recoverable AP-1 CCR had been relocated into the consolidated lined area. The progression of activities would be from south to north, as shown on the phasing plans in the Closure Drawings.

Incremental Final Cover System Installation (Final Capping) – As part of the phased closure approach, it is planned to conduct final capping (i.e., install the final cover system) incrementally from south to north in coordination with the filling of cells in the consolidated lined area, as areas are brought to the specified final grades.

Final Phase – Complete Final Closure. Closure construction will be completed during this phase and AP-1 will at that time transition from the closure period to the post-closure care period (upon completion of reporting activities discussed subsequently in this Closure Plan, and approval by GA EPD). The final closure condition is depicted on Drawings 17 through 19 of the Closure Drawings. Specific activities that will be conducted during this phase include:

- Complete installation of the final cover system over the consolidated lined area;

- Complete installation of stormwater management features above the final cover system;
- Fill and grade the other areas beyond the consolidated lined area (i.e., AP-1 areas primarily to the north and south of the limits of the consolidated lined areas), and construct final closure stormwater management systems to promote stormwater runoff away from the consolidated lined area;
- Remove and/or lower portions of the original AP-1 perimeter dike that are no longer needed to facilitate stormwater management and improve site aesthetics; removed fill may be used for other grading and construction purposes; and
- Implement the inspections, operations and maintenance (O&M) and monitoring requirements of the Post-Closure Plan.

5.4 PROCEDURES DURING CLOSURE

5.4.1 Dewatering and Stabilization

Dewatering of AP-1 will be performed by removing free water (i.e., open pooled water) in AP-1 and reducing the water content of the CCR. Dewatering will occur throughout the closure construction process using both in-situ and ex-situ dewatering techniques. Examples of in-situ dewatering techniques that will be considered for use include trench drains, wellpoints, deep wells, and wick drains. Examples of ex-situ dewatering techniques that will be considered for use include gravity dewatering (settling basins), belt filter press dewatering, recessed chamber filter press dewatering, centrifuge dewatering, geotextile tube dewatering, windrowing, and absorbent desiccation. The closure contractor will have the latitude to propose dewatering means and methods to best meet the project requirements in a way that satisfies the design criteria and requirements. During closure, specific contractor-proposed means and methods will be submitted to and approved by GPC.

Dewatering is expected to facilitate removal, relocation, and consolidation of the CCR in the consolidated lined area. Dewatering is also expected to increase geotechnical slope stability of the CCR unit, reduce CCR consolidation settlement, improve constructability, and provide safe access for construction equipment.

5.4.2 Liquids Management

Closure construction will involve a dewatering program that includes removing free liquids from AP-1 and reducing the water content of the CCR in AP-1. Closure activities will also result in the generation of contact water and leachate. Throughout closure construction, liquids that have been in contact with or generated from CCR will be managed as follows:

- Dewatering will be performed as described previously. Water generated through AP-1 dewatering activities will be considered contact water (as defined below) and will be treated in an on-site WWTS or otherwise managed in accordance with the National Pollutant Discharge Elimination System (NPDES) permit requirements and the GA EPD-approved Dewatering Plan, and then directed to the permitted NPDES discharge outfall (Permit No: GA0001449, Outfall: 01A).
- Contact water (i.e., water that has been in contact with CCR and non-contact water that becomes mixed with contact water) management will be performed as described in Section 5.4.6 of this Closure Plan. Contact water may also be applied to CCR in AP-1 if needed for fugitive dust control. Contact water will be routed through the on-site WWTS or otherwise managed in accordance with the NPDES permit requirements and the GA EPD-approved Dewatering Plan as described above.
- Leachate generated from the CCR placed in the lined cells is also defined as contact water and will be managed in accordance with the leachate management procedures described in Section 5.4.7 of this Closure Plan. Leachate will be routed through the WWTS or otherwise managed in accordance with the NPDES permit requirements prior to discharge at the permitted NPDES outfall.

Non-contact stormwater will be managed in accordance with applicable stormwater and erosion and sediment control requirements and will be used on-site or conveyed through appropriate stormwater management features and erosion and sediment controls.

5.4.3 Excavation of CCR

Dewatered CCR in AP-1 will be mechanically excavated and transported using haul trucks. During the first phase, the excavated CCR will be transported to one or more temporary stockpile(s) in the northern and/or central portion of AP-1 to make room for construction of the first cells of the consolidated lined area. Temporary stockpiles may receive temporary covers depending on their location and the length of time they will exist. During subsequent phases, the excavated CCR will likely be transported directly to lined cells for disposal. With this approach, double-handling of CCR is minimized to the extent possible.

5.4.4 CCR Removal Verification Protocol

The “CCR removal verification protocol” refers to the process of verifying and documenting that, to the extent practicable, CCR has been removed from the unit. The CCR removal criteria and verification protocol that will be followed is set forth in the Construction Quality Assurance (CQA) Plan included in Section 5 of Part A of the permit application.

5.4.5 CCR Placement and Compaction

The method of CCR placement will be the area fill method which involves placing relocated CCR in the lined cells, spreading the CCR in layers (lifts) and then compacting the CCR with heavy equipment. This process is repeated until the top of CCR elevations shown on the Closure Drawings are reached. CCR placement and compaction efforts will be conducted in general accordance with the requirements below:

- Dewatered CCR will be transported from excavated or stockpiled areas.
- CCR will be placed in lined cells in relatively horizontal lifts to facilitate efficient compaction of placed materials.
- The active CCR-placement working area will be limited to the extent practical to limit leachate generation and the potential for dust generation. Proper dust control measures will be implemented as described subsequently.
- The placed CCR will be compacted (and moisture conditioned as necessary) such that the ash surface is firm and unyielding after several passes of the compaction equipment.
- Sediments deposited as a result of erosion may be present at the toes of slopes and in temporary contact-water drainage ditches and storage areas. Prior to CCR placement following periods of inclement weather, these areas of potential sedimentation will be inspected. Soft or loose CCR material will be removed and placed back into the active working area for drying and compaction, as needed.
- The working surface or face will be graded in such a way to minimize the run-on/run-off of stormwater.
- At the end of each day's activities, the working surface will be seal-rolled with a smooth drum roller or other suitable methods. Prior to placement of subsequent lifts, sealed CCR surfaces will be lightly scarified using a dozer or other equipment to promote lift bonding.

The compacted CCR material will support the final cover system with only limited short- and long-term settlements. At the outset of CCR placement in the lined cells, field testing may be performed to evaluate the optimum material placement methods (lift thickness, optimum moisture window, type of compaction equipment, and number of passes). Modifications to the general placement procedures described above will be incorporated into the construction process based on the actual field conditions encountered (e.g., variability in ash properties and placement operations, dust control, material workability, etc.).

5.4.6 Stormwater and Contact-Water Management

5.4.6.1 AP-1 Overall

Overall, closure activities will take place within the limits of the existing outer perimeter containment dikes of AP-1. These dikes prevent run-on from and run-off to areas outside of AP-1. The Engineering Report in Section 3 of Part B of the permit application includes interim condition stormwater calculations to address the hydrologic and hydraulic capacity requirements for AP-1 and how they will be met during closure construction to manage flows from the inflow design flood.

5.4.6.2 Active Closure Construction – Non-Contact Stormwater Run-On Control

During closure construction, the generation of contact water due to run-on to, and run-off from, active CCR working areas will be limited to the extent practical. Non-contact stormwater will be diverted away from and around active CCR working areas to minimize the generation of leachate and contact water through the use of: (i) intercell berms that divide the lined cells; (ii) diversion berms positioned on slopes situated up-gradient from the working areas; and (iii) diversion channels positioned around working areas. The Closure Drawings illustrate, and the Engineering Report in Section 3 of Part B of the permit application contains additional information on, the location and sizing of these features.

Additionally, because each cell will cover several acres, a rain flap (see Closure Drawing details) may be installed in a lined cell to form a diversion/divider between areas not yet receiving CCR and those active areas where CCR has been placed. The purpose of a rain flap is to divide a cell into smaller, more manageable areas for the purpose of more efficient leachate/contact water management (minimize generation), and to prevent erosion of, and sediment migration into, the LCRS. As shown on the Closure Drawings, a rain flap is a temporary stormwater control device that uses a section of geomembrane liner that is welded perpendicular to the drainage portion of the constructed cell liner in a traversing manner. Rain flaps separate cells into an area receiving CCR, from which leachate/contact water can be extracted and properly managed, and a separate area not yet receiving CCR, from which non-contact water can be removed without having to manage it as leachate/contact water (since it has not come in contact with CCR). Once the amount of CCR received is sufficient for the lift to cover the entire cell, the rain flap is removed and the remainder of the cell will receive CCR.

5.4.6.3 Active Closure Construction – Contact Water Run-Off Control

During closure construction, contact water will be conveyed to temporary management/collection areas (low points and set-backs) next to the work areas where it will be removed and transferred to composite-lined contact-water storage ponds. These temporary ponds will be underlain by a composite liner consisting of a geomembrane upper component and a compacted clay liner (CCL) or geosynthetic clay liner (GCL) lower component. As water accumulates in a lined storage pond, it will be pumped to the on-site temporary WWTS located southeast of AP-1 as shown on the Closure Drawings.

The temporary contact-water management/collection areas will be located adjacent to active work areas and surrounded by berms sized according to the criteria described in the Engineering Report in Section 3 of Part B of the permit application. These temporary contact-water management/collection areas will be located within AP-1 adjacent to active CCR excavation, stockpile, and placement areas, either on existing CCR stack areas, in excavation areas adjacent to lined cells, or on CCR placed in lined cells.

The phasing plans shown on the Closure Drawings depict the configuration of AP-1 at various points in the sequence of closure. These drawings include conceptual designated areas for contact-water collection that are strategically positioned near and down-grade from active CCR excavation and placement operations, as well as designated areas within AP-1 where the lined contact-water storage ponds will be located. It should be recognized that the phased nature of the closure activities (CCR excavation, lined cell development and filling, and phased installation of the final cover system) will result in the need for periodic adjustments to the contact-water collection areas, and the creation and periodic movement of diversion ditches/berms to route contact water to those areas. Similarly, there are several lined contact-water storage pond locations designated for different phases of construction – at any given time, at least one lined contact-water pond will be in use.

5.4.7 Leachate Management

During closure construction, LCRS monitoring and operation will commence in a given cell when CCR placement begins in that cell. LCRS monitoring and operation will continue throughout the active life of the cell. Monitoring will be continued through the the post-closure care period and the system will be operated to the extent that leachate generation occurs during this period. The leachate

management system has been designed according to the criteria described in the Engineering Report in Section 3 of Part B of the permit application. Associated leachate management system calculations are also included in the Engineering Report.

Leachate percolating through the CCR in the lined cells will be collected in the LCRS and will flow by gravity to a leachate collection corridor or directly into sumps. Leachate sumps at the low point of each lined cell will be equipped with riser pipes from which collected leachate will be withdrawn using pumps housed in sideslope riser pipes and conveyed through a leachate transmission system. Leachate will be routed through the transmission system to the WWTS or otherwise managed in accordance with the NPDES permit requirements prior to discharge at the permitted NPDES outfall.

5.4.8 Fugitive Dust Control Plan

The purpose of this fugitive dust control plan is to demonstrate compliance with the fugitive dust requirements of State CCR Rule 391-3-4.10 and 40 CFR §257.80(b)(1) through (7). USEPA defines “CCR fugitive dust” as “solid airborne particulate matter that contains or is derived from CCR, emitted from any source other than through a stack, or chimney.” [40 CFR § 257.53; incorporated by reference in State CCR Rule 391-3-4.10(2)(a)].

This plan identifies and describes the CCR fugitive dust control measures that GPC will use during AP-1 closure construction to minimize airborne CCR due to construction and related activities associated with closure of AP-1. The CCR fugitive dust control measures that will be used are presented below.

- Fugitive dust originating from the closure of AP-1 will be controlled using water suppression or polymer tackifiers.
- CCR that is transported via truck will be conditioned to appropriate moisture content to reduce the potential for fugitive dust.
- Water suppression or polymer tackifiers will be used as needed to control fugitive dust on facility roads used to transport CCR and other CCR management areas.
- Speed limits will be utilized to reduce the potential for fugitive dust.
- Trucks used to transport CCR will not be overfilled (i.e., only filled up to or less than capacity) to reduce the potential for material spillage.

The fugitive dust control measures described above were selected based upon an evaluation of site-specific conditions at AP-1, including the physical properties of CCR, the specific closure construction activities, weather conditions, and operating conditions.

GPC personnel and/or their contractors will assess the effectiveness of the control measures by performing visual observations of AP-1 and surrounding areas and implementing appropriate corrective actions for fugitive dust, as necessary. Logs will be used to record the utilization of water-spray equipment.

Should a complaint be received from a citizen regarding a CCR fugitive dust event at the facility, the complaint will be documented and investigated. Appropriate steps will be taken, including any corrective action, as appropriate.

In accordance with §257.80(b)(6), (7), and (d), the fugitive dust control plan will be amended whenever there is a change in conditions that would substantially affect the plan. Annual fugitive dust control reports will be prepared and placed in the facility's operating record as required by §257.80(c).

5.4.9 Equipment Decontamination

Before removing a piece of equipment that has been in contact with CCR from the active work area of AP-1, the equipment will be cleaned with water. CCR residues generated during this cleaning will be placed in AP-1 for disposal prior to completion of the final cover system. Water generated from this activity will be managed as contact water.

5.4.10 Inspections

The following inspections are performed in accordance with State CCR Rule 391-3-4-.10(5)(b):

- 7-Day Inspections. GPC inspects the CCR unit and discharge of all hydraulic structure outlets at intervals not exceeding seven (7) days. The 7-day inspections are made by a qualified person and include observation and documentation of any appearance of actual or potential structural weakness and other conditions which are disrupting or have the potential to disrupt the operation or safety of the facility.
- 30-Day Inspections. GPC monitors all CCR unit instrumentation at intervals not exceeding 30 days. These instrumentation monitoring examinations are made by a qualified person.
- Annual Inspections. A qualified professional engineer (P.E.) registered in Georgia inspects the CCR unit on an annual basis to ensure that the design, construction, operation, and maintenance of the CCR unit is consistent with recognized and generally accepted good engineering standards. The inspection includes, at a minimum, the following activities:
 - i. A review of available information regarding the status and condition of the CCR unit, including, but not limited to, files available in the operating record (e.g., CCR unit design and construction information required by §§

- 257.73(c)(1) and 257.74(c)(1), previous periodic structural stability assessments required under §§ 257.73(d) and 257.74(d), the results of inspections by a qualified person, and results of previous annual inspections);
- ii. A visual inspection of the CCR unit to identify signs of distress or malfunction of the CCR unit and appurtenant structures; and
 - iii. A visual inspection of any hydraulic structures underlying the base of the CCR unit or passing through the dike of the CCR unit for structural integrity and continued safe and reliable operation.

The results of this annual inspection are presented in a report that is placed in the facility's operating record as well as on the GPC CCR Compliance website. The annual inspection report will address the following: (i) any changes in geometry of the impounding structure since the previous annual inspection; (ii) the location and type of existing instrumentation and the maximum recorded readings of each instrument since the previous annual inspection; (iii) the approximate minimum, maximum, and present depth and elevation of the impounded water and CCR since the previous annual inspection; (iv) the storage capacity of the impounding structure at the time of inspection; (v) the approximate volume of impounded water and CCR at the time of the inspection; (vi) any appearances of an actual or potential structural weakness of the CCR unit, in addition to any existing conditions that are disrupting or have the potential to disrupt the operation or safety of the CCR unit and appurtenant structure; and (vii) any other changes which may have affected the stability or operation of the impounding structure since the previous annual inspection.

If a potential deficiency or release is identified during an inspection, GPC will remedy the deficiency as soon as feasible. If needed, GPC will activate the Emergency Action Plan and follow the appropriate procedures outlined in that plan. GPC will prepare documentation detailing the corrective measures taken and will place it in the facility's operating record.

5.5 CLOSURE DESIGN FEATURES

5.5.1 Lined Area Subgrade (Foundation)

The entire floor of the consolidated lined area, plus the area beneath the new north and south containment dikes will undergo foundation improvement by: (i) excavation to specified grades in the residuum layer that will be exposed once the CCR is removed; (ii) proof-rolling of the foundation using a heavy compactor or other suitable equipment; (iii) treatment (using grouting, graded rock filters, or other suitable methods approved by GPC and the Design Engineer) of any historical cover-collapse depressions or drop-outs encountered in the excavation; and (iv) backfilling the excavation with a bridging/buffer layer of compacted soil to the specified liner system grades. The purpose of the foundation improvements is to provide reliable long-term foundation support for the AP-1 consolidated lined area.

Refer to the Foundation Improvement Plan in Appendix A of this Closure Plan for a description of the specific procedures and requirements that will be followed to evaluate the foundation and implement the improvements.

5.5.2 Composite Liner

The consolidated lined area will be subdivided into 12 lined cells, all underlain by a liner system consisting of a lower composite liner component and upper LCRS component. The composite liner will include a 60-mil (minimum) thick high-density polyethylene (HDPE) geomembrane underlain by a compacted clay liner (CCL) or geosynthetic clay liner (GCL). The bottom of the lined area will be designed to maintain a 5-foot (minimum) separation distance between the anticipated seasonally-high post-closure groundwater level and the base of the composite liner (with the exception of the sumps, which are designed to maintain an approximately 3-foot or greater separation distance, and all of which will be equipped with leachate removal pumps and a double-liner system as shown on the Closure Drawings).

The liner system has been designed to avoid the potential for uplift for groundwater levels at least 10 to 20 feet higher (depending on the cell) than the predicted post-closure seasonal high groundwater levels presented in the permit application. The components of the closure design, including the liner elevations, the planned CCR dewatering program, and the removal of CCR during construction accounts for the potential for liner system uplift. The Engineering Report in Section 3 of Part B of the permit application includes uplift calculations demonstrating the uplift resistance of the liner system for the anticipated site-specific conditions.

During closure activities, the planned CCR dewatering program and the progressive construction of lined cells are expected to lower the current groundwater elevations beneath AP-1 such that there is no potential for liner system uplift during construction and/or initial cell operation (just prior to the start of CCR placement). Nonetheless, during liner system construction and initial cell filling, groundwater elevations will be continuously monitored to confirm they are below the elevations that could potentially induce hydraulic uplift. Although very unlikely, if the instrumentation were to reveal the potential for uplift during cell construction or initial operation, additional dewatering measures would be used to lower groundwater levels and/or ballast (e.g., granular fill, or CCR if the cell is ready to receive it) would immediately be placed in the bottom of the cell in the sump area. Note, that any area requiring ballast for this unlikely scenario would be very small (i.e., around the sump location) and ballast thickness would likely not be more than a few feet.

The composite liner has been designed to have adequate durability and service life characteristics and sufficient strength and thickness to not fail due to the climatic, pressur, stress, and other conditions to which it will be exposed, or to exposure to CCR or leachate. A testing and documentation program will be conducted during

construction of the composite liner to provide verification that the liner materials are constructed in accordance with the specifications. Composite liner material property requirements, and quality control and conformance testing methods and frequencies, are provided in the CQA Plan included in Section 5 of Part A of the permit application.

5.5.3 Leachate Collection and Removal System (LCRS)

The LCRS has been designed and will be constructed, operated, and maintained to collect and remove leachate during both the active life (i.e., the period of activities to implement closure) and post-closure care period while limiting the buildup of leachate head on the composite liner to less than 30 centimeters (1 foot) (except in the LCRS removal sumps that will be double-lined). A testing and documentation program will be conducted during installation of the LCRS to provide verification that the materials and components are constructed in accordance with the specifications. LCRS material property requirements, and quality control and conformance testing methods and frequencies, are provided in the CQA Plan included in Section 5 of Part A of the permit application.

To facilitate leachate drainage in the LCRS, the lined cell floors will be graded at 2 percent minimum slopes toward leachate collection corridors sloped at a minimum of 1 percent that drain to leachate collection sumps at low points near the perimeter of each cell. As previously described, collected leachate will be pumped through forcemain piping to an on-site WWTS or otherwise managed in accordance with the NPDES permit requirements prior to off-site discharge via the permitted site NPDES outfall.

Additional details regarding the design of the LCRS and the overall leachate management system are provided in the Engineering Report in Section 3 of Part B of the permit application.

5.5.4 Final Cover System

The final cover system has been designed and will be installed over the final CCR grades to minimize infiltration and erosion. Two alternative final cover system options are proposed for the consolidated lined area. The first option would consist of, from bottom to top, a 40-mil (min) thick textured HDPE or linear-low density polyethylene (LLDPE) geomembrane, a double-sided geocomposite drainage layer, an 18-inch thick protective soil layer, and a 6-inch thick vegetative cover layer. The second option would consist of ClosureTurf® (i.e., a 50-mil thick HDPE or LLDPE geomembrane, engineered turf, and a minimum ½-inch thickness of sand infill). Details of both final cover systems are provided on the Closure Drawings. If the soil-geosynthetic final cover system option is selected, the soil will be obtained from on-site borrow areas and stockpiles, or other GPC-approved borrow source areas, as necessary.

The final cover system is designed to meet the following design standards of 40 CFR §257.102 (d) (incorporated by reference in State CCR Rule 391-3-4-.10(7)(b)):

- a. Control, minimize or eliminate, to the maximum extent feasible, post-closure infiltration of liquids into the waste and releases of CCR, leachate, or contaminated run-off to the ground or surface waters or to the atmosphere;
- b. Preclude the probability of future impoundment of water, sediment, or slurry;
- c. Include measures that provide for major slope stability to prevent the sloughing or movement of the final cover system during the closure and post-closure care period;
- d. Minimize the need for further maintenance of the CCR unit; and
- e. Be completed in the shortest amount of time consistent with recognized and generally accepted good engineering practices.

A testing and documentation program will be conducted during placement of the final cover system to provide verification that the final cover materials are constructed in accordance with the specifications. Final cover system material property requirements, and quality control and conformance testing methods and frequencies, are provided in the CQA Plan included in Section 5 of Part A of the permit application.

As previously described, final cover design grades range from 4 percent to 33 percent (3H:1V) except for stormwater drainage conveyance features on the final cover system (i.e., drainage berms, drainage terraces and perimeter channels) which will have slopes generally ranging from 0.5 percent to 2.0 percent.

5.5.5 Stormwater Management System

The stormwater management features shown on the Closure Drawings will be constructed to manage stormwater runoff during both closure construction and the post-closure care period. The final closure grades incorporate stormwater management features to prevent erosion and direct stormwater runoff into the stormwater management system. The Closure Drawings include the layout and details of the stormwater management system, including required erosion and sediment controls. Diversions and channels will be constructed on the final cover system and around the perimeter of the consolidated lined footprint and to divert run-on to and convey runoff from the site in a controlled manner. The design criteria, narrative descriptions, and calculations for the stormwater management system during closure construction and after final closure are provided in the Interim Conditions Stormwater and Contact Water Management System Design and the Final Cover Stormwater Management System Design, both of which are included in the Engineering Report in Part B, Section 3 of the permit application.

5.6 ACHIEVEMENT OF CLOSURE PERFORMANCE STANDARDS

Closure of AP-1, as reflected in this Closure Plan and the accompanying permit application package, is designed and will be constructed to achieve applicable closure performance standards of 40 CFR §257.102(d) (incorporated by reference in State CCR Rule 391-3-4-.10(7)(b)) for the reasons described below.

- The final cover system will control and minimize infiltration of liquids into the CCR, release of CCR into the environment, and flow of contaminated runoff from AP-1 to groundwater or surface waters, or to the atmosphere. This will be accomplished by using a virtually impermeable geomembrane as part of the final cover system. The geomembrane will isolate the CCR from the surrounding environment and essentially eliminate infiltration into the CCR relative to existing conditions. The final cover system will be installed over the entire consolidated lined area, eliminating direct exposure of CCR to the surrounding environment.
- In addition to the role of the final cover system in minimizing infiltration of liquids and release of CCR into the environment, the entire AP-1 consolidated closure area will be underlain by a composite liner and an LCRS. The presence of the virtually impermeable composite liner will further enhance the isolation of CCR from the surrounding environment. Former areas of AP-1 outside of the consolidated lined area will be graded and vegetated to promote stormwater runoff away from the consolidated lined area.
- Both proposed final cover system options are alternatives to the final cover system prescribed in 40 CFR §257.102(d)(3)(i), and both options have been designed and will be constructed to achieve an equivalent reduction (and in fact, a greater reduction) in infiltration into the CCR as would be achieved with the prescriptive final cover system. The proposed final cover system options will also have erosion layers that provide equivalent protection from wind and water erosion as the erosion layer of the prescribed final cover. An equivalency demonstration is presented in the final cover system calculations in the Engineering Report included as Part B, Section 3 of the permit application.
- The final cover system is configured to preclude the probability of future impoundment of water, sediment, or CCR slurry in AP-1. This will be accomplished by the grading and layout of the final cover system, and by the stormwater management and control system that will be installed (resulting in positive drainage for stormwater runoff from the final cover system and limiting stormwater run-on). Surface-water conveyance structures are designed with appropriate channel lining materials to resist erosion during the design storm event and to minimize surface water infiltration.
- The consolidated lined area has been designed and will be constructed with measures that provide for adequate levels of slope stability, that prevent the sloughing or movement of the final cover system, and that minimize the potential for disruption of final cover system due to settling or subsidence. Slope stability factor of safety design

criteria will be achieved for static, seismic, liquefaction, and end-of-construction conditions for both the closure and post-closure care periods. An evaluation of the veneer stability of the final cover system has also been performed to quantify the interface shear strengths necessary to meet minimum design factors of safety for both static and seismic conditions. Geotechnical stability and settlement calculations are presented in the Engineering Report included as Part B, Section 3 of the permit application.

- The final cover system is designed to minimize the need for further maintenance of AP-1. This will be accomplished by consolidating CCR within AP-1 from an approximately 254-acre area into an approximately 144-acre area, thereby reducing the total area requiring maintenance by about 43 percent. Additionally, the stormwater management system features on the final cover and in adjacent final closed areas are configured and spaced in a manner to minimize post-closure erosion and adequately handle flows from the design storm, also contributing to minimized need for post-closure maintenance of AP-1.
- Final cover system construction will be completed in the shortest amount of time consistent with recognized and generally-accepted and appropriate engineering practice. This will be accomplished by using a phased construction approach designed to allow closure construction to be efficiently implemented. As final CCR elevations are reached in phases during closure construction, the final cover system will be installed incrementally on those areas while other phases of AP-1 closure are either being filled, prepared for filling, and/or dewatered. This approach will allow multiple construction activities to be performed in parallel, shortening the total construction duration compared to conducting the construction activities in series.
- This Closure Plan includes provisions for eliminating free liquids and stabilizing the CCR through dewatering and through CCR placement and compaction methods prior to installing the final cover system.

5.7 MAXIMUM INVENTORY OF CCR

AP-1 currently contains an estimated approximately 20.4 million cubic yards of in-place CCR (which includes about 0.2 million cubic yards of native soil that will be excavated along with the CCR as part of the closure process), all of which will be placed into the consolidated lined area.

5.8. LARGEST AREA REQUIRING FINAL COVER

Based on the closure strategy presented herein, all the CCR in AP-1 will be moved to the 144-acre consolidated lined area. This entire area will receive final cover. Thus, the largest area ever requiring final cover under the proposed closure is 144 acres.

5.9 SCHEDULE FOR COMPLETING ACTIVITIES

It is estimated that the activities necessary to satisfy the applicable regulatory closure criteria will have an approximately 15-year duration. Since the closure schedule is anticipated to exceed five years, GPC will request two-year extensions as necessary to complete closure. Each two-year extension request (up to five total) made to the GA EPD Director will provide the factual circumstances demonstrating the need for extension.

A list of closure activities/milestones and schedule with estimated approximate timeframes is provided subsequently in Section 15 of this Closure Plan. The closure schedule and milestones are based on estimates of the approximate timeframes to implement each specific closure activity. Closure will be conducted in phases as discussed previously, but it should be recognized that not all activities on the closure schedule will occur on a continuous basis throughout their scheduled durations, consistent with the previously-described sequence of closure steps.

6. DRAINAGE AND STABILIZATION

The closure design described in Section 5 of this Closure Plan will eliminate free liquids from AP-1, and the remaining CCR will be stabilized by dewatering, placement, and compaction, sufficiently to support the final cover system.

7. CERTIFICATION OF CLOSURE

In accordance with State CCR Rule 391-3-4-.10(7)(e) and 40 CFR §257.102(f)(3), upon completion of closure activities, a P.E. registered in Georgia will prepare and GPC will submit a closure report to the GA EPD Director. The closure report will be completed on forms provided by GA EPD. Once the GA EPD Director concurs with the closure report, closure will be deemed complete and the site will begin the post-closure care period.

Following closure, GPC will record a notation on the deed to the property, inclusive of the AP-1 permit boundary, that will in-perpetuity notify any potential purchaser of the property that the land has been used as a CCR unit and that its use is restricted under the post-closure care requirements of State CCR Rule 391-3-4.10(7)(f). Within 30 days of recording the property deed notation, GPC will submit to GA EPD a notification stating that a notation on the property deed has been recorded.

8. DIRECTIONAL INFORMATIONAL SIGNS

Signs will be posted at the entrance gate notifying users of AP-1 of the closure and a telephone number for emergencies will be printed on the sign.

9. REMOVAL OF CCR FOR BENEFICIAL USE OR LANDFILL DISPOSAL

9.1 REMOVAL OF CCR FOR BENEFICIAL USE

CCR is proposed to be reclaimed from AP-1 during the closure period for beneficial use as defined in 40 CFR §257.53. The quantity of CCR that may be reclaimed is unknown, largely because the demand for the product fluctuates based on market conditions. The CCR removal plan for beneficial use presented below describes the measures that will be implemented during CCR reclamation for beneficial use during closure of AP-1.

- CCR reclamation will occur concurrently (and in a manner that does not interfere) with closure construction.
- Contact water generated at CCR reclamation areas will be removed and managed as contact water in the same manner as described herein for the closure activities.
- Dust control measures at CCR reclamation areas will be implemented in the same manner as described herein for the closure activities.
- The quantity of CCR reclaimed from AP-1 will be tracked and documented by GPC on an ongoing basis. The total volume of CCR removed from AP-1 for beneficial use will be included in the certified closure report described in Section 7 of this Closure Plan.
- Reclamation of CCR that has already been placed into the consolidated closure footprint (i.e., the lined cells) will not occur during the closure period (nor will it take place during the post-closure care period) unless approved by GA EPD.

As a consequence of reclaiming of CCR for beneficial use during the closure period, the consolidated closure footprint may be revised to be smaller than currently shown on the closure drawings, or soil fill may be utilized to replace the CCR volume removed so as to achieve the original permit grades for the final cover system. If the consolidated footprint is reduced, GPC will prepare and submit to GA EPD a permit modification request for the revised closure design grades.

9.2 REMOVAL OF CCR FOR LANDFILL DISPOSAL

To facilitate the AP-1 closure approach described herein, during the AP-1 closure period, some of the CCR from AP-1 may be removed and transported to the permitted on-site Plant Bowen Ash Landfill for disposal, or to an off-site solid waste handling facility that has been permitted to receive such waste. CCR removed from AP-1 for landfill disposal will be subject to the applicable requirements of the receiving facility's permit.

The quantity of CCR from AP-1 that may be removed for landfill disposal is unknown, as it is dependent on a variety of factors such as schedule and construction logistics needs of

the closure project, as well as the available disposal capacity of the receiving landfill, beneficial use, and other considerations.

The quantity of CCR removed from AP-1 for landfill disposal will be tracked and documented by GPC on an ongoing basis. The total volume of CCR removed from AP-1 for landfill disposal will be included in the certified closure report described in Section 7 of this Closure Plan.

Similar to the situation described above for potential beneficial use, as a consequence of CCR transferred from AP-1 to a landfill for disposal during the closure period, the consolidated closure footprint may be revised to be smaller than currently shown on the closure drawings, or soil fill may be utilized to replace the CCR volume removed so as to achieve the original permit grades for the final cover system. If the consolidated footprint is reduced, GPC will prepare and submit to GA EPD a permit modification request for the revised closure design grades.

10. VEGETATIVE PLAN

The consolidated lined area will be final capped with either a soil-geosynthetic final cover system with a topsoil layer on the surface, or a synthetic engineered turf final cover system. Additionally, graded areas within the project limit-of-disturbance but outside of the final cover system will have a vegetated soil surface (with the exception of lined ditches, gravel roads, etc.). To promote growth of vegetation, the vegetative layer of the final cover system and the soil ground surface of disturbed project areas will be seeded, limed, and fertilized within two weeks of the layer's installation. The types of vegetation to be seeded, the applicable planting dates, and the associated seed and fertilizer specifications, application rates, and application methods will comply with the Disturbed Area Stabilization (With Permanent Vegetation) details in the Closure Drawings. The source of these details is the Georgia Water Soil Conservation Commission (GWSCC).

Seedbed preparation, consisting of tillage (or pitting or trenching for steep slopes) and lime and fertilizer incorporation will occur prior to conventional seed planting methods. Although not required, seedbed preparation will be used, if judged beneficial, for hydraulic seed planting methods (in this case, lime and fertilizer would be incorporated into the slurry mix). Upon planting, mulching will be required for permanent vegetation applications.

During temporary lapses in construction activity, temporary stabilization measures will be installed on exposed areas within 14 days of disturbance and in accordance with the Disturbed Area Stabilization (With Mulching Only) or Disturbed Area Stabilization (With Temporary Seeding) details in the Closure Drawings. These details are also from GWSCC.

For the ClosureTurf® final cover system option, the system is composed of a geomembrane overlain by an engineered synthetic turf and sand infill material. Vegetation will not be required for areas final covered with ClosureTurf®.

11. SITE EQUIPMENT NEEDED

GPC will make adequate equipment available to ensure that closure requirements are executed correctly and efficiently. Should said equipment not be available, backup equipment may be obtained from rental companies.

12. SEDIMENT REMOVAL

On a periodic basis during closure, accumulated sediment will be removed when necessary from drop inlets, drainage pipes, diversion ditches, and other drainage structures.

13. EROSION AND SEDIMENT CONTROL

Upon closure, all ditches, diversion berms, culverts, rip-rap, and other drainage structures serving disturbed areas, but not already built, will be constructed and placed according to the Closure Drawings.

14. COST OF CLOSURE AND FINANCIAL ASSURANCE

The closure cost estimate is provided in Table 1 at the end of this document. In compliance with applicable securities laws and regulations, GPC will provide unredacted cost estimate for closure to GA EPD under separate cover. The closure costs include all items necessary for a third-party to complete the project in accordance with the Closure Plan as set forth herein. The closure cost estimate is based on the largest area requiring final cover (i.e., 144 acres) and is generated in current dollars. The cost estimate will be adjusted annually for inflation. GPC will provide a demonstration of financial assurance upon approval of the closure and post-closure care cost estimates by GA EPD.

15. CLOSURE SCHEDULE

The schedule of major milestones and approximate timeframes shown below will be followed over the approximately 15-year closure period:

- Remove free liquids and conduct CCR dewatering – approx. 13 years.
- Excavate CCR and conduct foundation improvements – approx. 13.5 years.
- Install the composite liner system (construct lined cells) and the associated leachate collection, recovery, and transmission system – approx. 11 years.
- Place, grade, and compact relocated CCR into lined cells – approx. 13.5 years.

- Install final cover system and stormwater management features – approx. 11 years.

Closure will be conducted in sequential steps consistent with the phases discussed previously, but it should be recognized that not all activities on the closure schedule will occur on a continuous basis throughout their scheduled durations, and that the timeframes are only estimates. It is estimated that closure activities for AP-1 will be completed in the year 2035.

In accordance with the requirements of 40 CFR §257.102(h), within 30 days of the completion of closure of AP-1, GPC will prepare and place into the facility's operating record, a notification of closure of the CCR unit.

16. RECORDKEEPING/NOTIFICATION/INTERNET REQUIREMENTS

GPC will comply with the requirements of State CCR Rule 391-3-4-.10(8), which references the recordkeeping requirements of 40 CFR §257.105(i), the closure notification requirements specified in 40 CFR §257.106(i), and the closure internet posting requirements in 40 CFR §257.107(i).

17. LEGAL DESCRIPTION

A survey drawing (plat) and legal description of the permit boundary, prepared by a Registered Professional Surveyor, is included in the Closure Drawings. The as-designed final limit of CCR is defined on the Closure Drawings for the consolidated lined area. Upon completion of closure, the actual final limit of CCR will be confirmed and documented in the closure report.

TABLE 1
Closure Cost Estimate

Table 1 - Closure Cost Estimate
Ash Pond 1 Closure in Place Cost Estimate

Item Description	Quantity	Unit	Unit Cost	Cost
Program Management				
Regulatory Compliance, Fees & Reporting				
Groundwater Sampling & Reporting, Compliance Evaluations ¹				
AP Closure Construction				
<u>Construction Management, Construction Support</u>				
Construction Management				
Bonds & Insurance				
Support Facilities				
Engineering and CQA Construction Support				
Mobilization/Site Preparation and Demobilization				
<u>CCR - Excavate, Transport, Place, Manage</u>				
Stability and Performance Monitoring Equipment				
Organics Management				
Dust Control				
CCR Excavate, Conditioning for compaction, Transport, and Place & Compact ²				
<u>Foundation Improvements</u>				
Foundation Improvements (InSite Grouting, Solution Features Evaluation/Abatement) ³				
<u>Fill Material</u>				
Fill Material - Procure, Transport, Place Structural and Non-Structural Fill ⁴				
<u>Water Management (Stormwater, Leachate and Ash Pond Dewatering⁵)</u>				
Start Up Support (Electrical/Mechanical)				
Water Treatment				
Storm & Contact Water Management				
<u>AP Closure Liner Construction</u>				
AP Closure Liner Construction ⁶				
<u>AP Closure Cover System Construction</u>				
AP Closure Cover System Construction ⁷				
<u>Site Maintenance During Construction & Restoration</u>				
Site Maintenance During Construction & Restoration				
			Subtotal	
			Contingency	
			Total Closure Cost Estimate	

Notes:

1. Groundwater monitoring includes costs for conducting routine monitoring of App III & IV during the construction period.

4. Includes fill material from on-site and off-site sources, evaluation for chemical and geotechnical properties, procurement, transportation, and placement per the CQA Plan.

5. Category includes the management of storm water, leachate, CCR contact water, and operations associated with the in-situ dewatering of CCR during the closure.

APPENDIX A
Foundation Improvement
Plan

FOUNDATION IMPROVEMENT PLAN

PLANT BOWEN ASH POND 1 (AP-1) CLOSURE

BARTOW COUNTY, GEORGIA

FOR



Georgia
Power

JULY 2021



Geosyntec 
consultants

TABLE OF CONTENTS

1.	INTRODUCTION.....	1
1.1	PURPOSE	1
1.2	SITE GEOLOGY	1
1.3	HISTORY OF FOUNDATION IMPROVEMENT ACTIVITIES AT AP-1.....	2
1.4	ENGINEERING METHODS TO MITIGATE COVER-COLLAPSE POTENTIAL	3
2.	IDENTIFICATION, INVESTIGATION, AND IMPROVEMENT OF COVER-COLLAPSE FEATURES AND SOFT AREAS.....	4
2.1	OVERVIEW	4
2.2	PROOF-ROLLING.....	5
2.3	CHARACTERIZATION OF COVER-COLLAPSE FEATURES AND SOFT SPOTS.....	6
2.4	REMEDIATION PROCEDURES FOR COVER-COLLAPSE FEATURES.....	6
2.4.1	Overview	6
2.4.2	Option 1 – Graded Rock Filter	7
2.4.3	Option 2 – Soil/Geotextile Plug	7
2.4.4	Option 3 – Fill Grouting	8
2.5	EXCAVATION AND BACKFILLING AROUND ROCK PINNACLES.....	8
2.6	SOFT SPOTS	8
2.7	PLACEMENT OF COMPACTED FILL	8
3.	DOCUMENTATION	9
4.	REFERENCES.....	9

LIST OF FIGURES

- Figure 1 Small Cover-Collapse Feature Remediation using Graded Rock Fill
Figure 2 Large Cover-Collapse Feature Remediation using Soil/Geotextile Plug

LIST OF ACRONYMS

AP-1	Ash Pond-1
CCL	Compacted Clay Liner
CCR	Coal Combustion Residuals
CQA	Construction Quality Assurance
GPC	Georgia Power Company
GPS	Global Positioning System
GSWP	General Service Water Pond
SCS	Southern Company Services

1. INTRODUCTION

1.1 PURPOSE

This Foundation Improvement Plan was prepared in support of the design to close ash pond AP-1, an existing coal combustion residuals (CCR) surface impoundment at Georgia Power Company's (GPC) Plant Bowen (site), located in Bartow County near Cartersville, Georgia. As reflected in the closure permit application package, GPC is proposing to close AP-1 using a consolidated lined closure approach whereby the entirety of CCR within AP-1 will be excavated and consolidated into an approximately 144-acre, fully-contained engineered structure (composite-lined and final-covered area) that will be constructed in the south-central portion of the current AP-1 footprint.

The purpose of this Foundation Improvement Plan is to present the procedures that will be used to remediate observed cover-collapse features or soft areas identified through the excavation and proof-rolling activities described subsequently. These procedures represent one of the engineering methods being developed as part of the closure design to assure that the integrity of the AP-1 foundation and liner system will be maintained throughout the impoundment's post-closure period, pursuant to the requirements of the Federal CCR Rule that the "integrity of structural components of the CCR unit will not be disrupted".

1.2 SITE GEOLOGY

The AP-1 site is situated within the Great Valley District of the Valley and Ridge physiographic province in northwest Georgia. The Valley and Ridge province is characterized by long north-northeasterly trending ridges and flat valleys, resulting from the erosion of alternating layers of hard and soft sedimentary rock that were folded and faulted during the Appalachian orogeny (mountain building event). Extending from Alabama to New York, the Valley and Ridge transitions to the northwest into the Cumberland Plateau province and is bounded on the south and east by the Piedmont physiographic province.

The Knox Group bedrock that underlies the region was folded and faulted during the Appalachian orogeny. This bedrock extends to the western portion of Bartow County, including the AP-1 site. The majority of the Knox Group consists of thickly- to massively-bedded dolomite, with lesser amounts of limestone, mainly brown or tan in the lower part, and medium to light gray in the middle and upper parts. The bedrock is highly siliceous and upon weathering produces a thick mantle of cherty, silty, clayey residuum that, in the vicinity of AP-1, varies from approximately 10 to 70 feet thick.

The geologic and hydrologic characteristics of the Knox Group bedrock have been affected to varying degrees by karst processes. Over geologic time (hundreds of thousands to millions of years), dissolution of the dolomitic and limestone bedrock along fractures and joints has resulted in linear solution-enlarged features such as cavities and slot-shaped fissures in the rock. These features are often filled with sediment or weathered rock debris such that they become effectively plugged. Sometimes they are open such that they create preferential flow paths for groundwater.

Cover-collapse depressions and drop-outs are the most common types of karst-related feature found at the surface in the region underlain by Knox Group bedrock and several episodes of depressions and drop-outs have been observed in past years in and around AP-1. In the formation of the cover-collapse feature, a sediment filled cavity or fissure in the bedrock erodes, leading to the creation of a soil void in the residuum overlying the bedrock opening. With time, the soil arch over the void may weaken (due to access to moisture and downward seepage gradients) and eventually collapse. This collapse, in turn, may propagate upwards, manifesting itself at the ground surface in the form of a cover-collapse depression or drop-out. It is important to note that the subsidence and movement of the residuum and any overlying material occurs without any actual failure of the bedrock. Cover-collapse features in Knox Group bedrock are not associated with modern or active dissolution of the bedrock. The mechanisms that contribute to the development of cover-collapse features in the residuum involve:

- The existence of open solution features in the bedrock, such as solution-enhanced fissures and cavities;
- An elevated water table resulting in increased hydraulic head pressure and downward seepage gradients from the overlying residuum into the bedrock;
- The collapse or erosion of the residuum into the solution-enhanced joint system due to the downward seepage forces and gravity; and
- The progressive upward propagation of downward soil collapse or erosion under the forces of downward seepage and gravity.

When all these mechanisms are present, the formation of cover-collapse depressions and drop-outs is possible. However, if one or more of these conditions are mitigated, then these mechanisms are decoupled from the process and the risk of cover-collapse feature development is substantially reduced.

1.3 HISTORY OF FOUNDATION IMPROVEMENT ACTIVITIES AT AP-1

As various portions of the Plant Bowen facilities were constructed, soil and groundwater conditions in the subsurface were subject to changes, such as physical loading (due to fill, grading, and building loads), unloading (due to excavations), and localized mounding of groundwater and downward seepage gradients (due to the unlined ponds and free water in the sluiced ash). Some of these changes led to the mechanisms, described above, that favored the formation of cover-collapse depressions and drop-outs. In recognition of these conditions, and their potential to contribute to cover-collapse feature development, GPC and Southern Company Services (SCS) implemented a subsurface compaction grouting program at AP-1 starting in the late 1960's to improve the foundation beneath the impoundment. The injection of grout into the residuum and fractured bedrock fills void spaces, displaces and compacts soft materials, and strengthens the soil and bedrock, creating a bridging layer in the soil beneath the impoundment. These injections may also assist in mitigating the formation of cover-collapse features by reducing pathways of soil loss into solution-enhanced features in the bedrock.

Grouting operations began in 1968 at the Plant Bowen site during construction of the general service water pond (GSWP) north dike. These grout injections were focused in the upper bedrock horizon to improve the foundation for the dike prior to filling of the pond. Beginning in the early 1970's, seepage and a drop-out were observed in the vicinity of the GSWP, with additional seepage and sloughing reported in the late 1970's. In response to these events, weirs were constructed to better monitor the flow into and out of the ponds.

In the early 1990's, following more than 20 years of water storage at the GSWP and ash sluicing into AP-1, a drop-out with water loss occurred at the GSWP, prompting the injection of more than 6,000 cubic feet of grout to repair the drop-out feature. At that time, GPC and SCS began the development of plans to transition from wet ash sluicing to dry handling procedures. The late 1990's saw several additional small drop-out features form within the middle and northern portions of AP-1, and a larger cover-collapse in 2002 driven by the hydraulic heads in the impoundment.

SCS has continued with its grouting program at AP-1 up to the present. In addition to the grouting, several operational modifications were made at AP-1 to reduce the hydraulic loading (i.e., downward hydraulic gradient) within the footprint of the pond. From 2002 to 2017, several dewatering ponds within the AP-1 footprint were lined. In 2015, a final cover system was completed on the North Stack to reduce infiltration, and lined ponds for stormwater and low-volume wastewater were installed in 2016.

Following these foundation improvements and related site improvements, between 2002 and the present, except for three small subsidence features near the west portion of the north dike of AP-1 in 2008, no cover-collapse features have been observed within AP-1. Since 2002, approximately 325,000 cubic feet of grout have been injected into the residuum and bedrock underlying the pond and perimeter dikes and these efforts continue in the central portion of the North Stack area of AP-1 to continue improvement of the rock and soil foundation beneath the pond. Based on observations, it appears that the grouting program and other activities undertaken by GPC and SCS have been largely successful in reducing the potential for cover-collapse feature development at AP-1. The engineering methods discussed below will provide substantial additional protections against the potential for future cover-collapse feature development.

1.4 ENGINEERING METHODS TO MITIGATE COVER-COLLAPSE POTENTIAL

The closure system design includes several engineering methods to mitigate the potential for, and any adverse effects of, cover-collapse feature development beneath the closed AP-1. These engineering methods include:

- A composite liner and leachate collection and removal system (LCRS), collectively termed a "composite liner system" will be installed across the entire consolidated lined area to provide an essentially-impermeable hydraulic barrier below all CCR. The composite liner system will virtually eliminate the potential for leachate migration from the lined area into the subsurface, thus eliminating vertical seepage gradients in the residuum.

- An essentially-impermeable final cover system will be installed over the CCR to virtually eliminate the infiltration of precipitation into the CCR and the generation of CCR leachate.
- All stormwater conveyance ditches and detention ponds around AP-1 that are not yet lined, and any new stormwater conveyance ditches and detention ponds constructed as part of the AP-1 closure project, will be lined to prevent vertical seepage from these storage and conveyance features into the residuum.
- The foundation improvement method involves excavation of a portion of the residuum layer that would be exposed once the CCR is removed from within the AP-1 footprint, proof-rolling of the foundation using a heavy compactor or other suitable equipment, treatment (using graded rock filters or fill grouting) of any cover-collapse depressions or drop-outs encountered in the excavation, and backfilling the excavation with compacted fill to the specified liner system grades. The compacted soil layer will be thick enough to protect the overlying liner system should there be a void feature in the deeper residuum (i.e., near the residuum-bedrock interface that was not identified through the excavation and proof-rolling activities) at which the overlying soil arch collapses.

The principal engineering methods to assure that the “integrity of structural components of the CCR unit will not be disrupted” as required by the Federal CCR Rule are those described above that will virtually eliminate the downward seepage of water within the AP-1 closure footprint. With downward seepage virtually eliminated within the closure footprint, the potential for future cover-collapse feature development is also greatly reduced. Nonetheless, the foundation improvement is also included as part of the AP-1 closure design to provide additional assurance that the integrity of the AP-1 foundation and liner system will be maintained throughout the impoundment’s post-closure period. The remainder of this document presents the plan for conducting foundation improvements at AP-1.

2. IDENTIFICATION, INVESTIGATION, AND IMPROVEMENT OF COVER-COLLAPSE FEATURES AND SOFT AREAS

2.1 OVERVIEW

As just discussed, the purpose of the foundation improvement is to improve foundation conditions beneath the consolidated lined closure area, identify and remediate any cover-collapse features or areas of soft soils identified through the excavation and proof-rolling activities, create a bridging layer that will preserve the integrity of consolidated lined area in the event of a void collapse at the residuum-bedrock interface beneath the area, and provide for reliable long-term foundation support for AP-1 after closure. It is noted that this type of foundation improvement has been widely-used to improve foundation conditions for sites underlain by karst bedrock (Sowers, 1996). For example, foundation excavation and backfilling/strengthening at locations of historical depressions or drop-outs have been applied at other CCR units situated in karst geological settings.

Based on the conceptual framework summarized in the previous section of this document, the available information on the site geology, hydrogeology, soil conditions, and plan for closing AP-1, and the results of engineering analyses contained in the calculation package *Impact of Subsurface Void on Liner System Integrity* included in the “Engineering Report” tab in Section 3 of Part B of this permit application, the AP-1 foundation engineering method will conservatively include an approximately 15-foot thick soil bridging layer. The bridging layer will consist of a minimum of 10 feet of compacted soil to create a “void free” zone (i.e., a minimum of 8 feet of compacted structural fill and 2 feet of compacted clay liner (CCL)) and a zone of about 5 feet below the foundation that will be evaluated for the existence of voids and soft areas through heavy proof-rolling. The above-referenced calculation package provides the basis of the foundation improvement, evaluates the impact of a potential void collapse above the residuum-bedrock interface on the development of tensile strains in the geomembrane components of the composite liner system, and demonstrates the adequacy of the engineering method in providing for the structural integrity and performance of the closure system should a cover-collapse feature develop in the residuum beneath the bridging layer due to a void collapse.

As described in the document “*Closure Plan*”, CCR in AP-1 will be excavated and the residuum will be exposed. The entire consolidated lined closure area (i.e., the entire area over which the composite liner system will be installed, plus the alignment of the new sections of perimeter dike that will be constructed for the closure area) will undergo foundation improvement. First, the residuum layer will be excavated to specified depths that are sufficient to construct the approximately 15-foot thick bridging layer. Proof-rolling will then be performed at the bottom of the excavation. Proof-rolling is a state-of-the-practice engineering and construction technique used to locate soft or yielding zones in soil beneath the bottom of an excavation. Any cover-collapse features or soft areas identified at the bottom of the excavation will be remediated using graded rock filters or fill grouting. Once these remediation activities are complete, the excavation will be backfilled with compacted fill (i.e., compacted structural fill and compacted clay liner) to the specified liner grades (i.e., top of CCL or bottom of geomembrane). The excavation grading plan for the AP-1 closure is shown on Drawing 8 of the Closure Drawings included in Section 9 of Part A. Note that the foundation improvement will be implemented in phases, in coordination with the passed closure of AP-1, as shown on the closure drawings.

The procedures that will be used to implement the foundation improvements are described below. As part of the detailed design of the AP-1 closure, these procedures will be further developed, and a set of construction specifications prepared that the closure contractor will be required to follow.

2.2 PROOF-ROLLING

As part of the detailed design, construction drawings will be prepared with excavation survey control points. The contractor will excavate the residuum as required by these drawings. If necessary, the excavation grades will be adjusted during closure construction based on the actual conditions encountered in the field.

Proof-rolling will be performed using a loaded articulated truck or other approved heavy equipment that exerts comparable ground pressures. Proof-rolling will involve 3 to 4 passes over the entire area. The proof-rolling activities will be observed and documented by Construction Quality Assurance (CQA) Consultant. If cover-collapse features or soft areas are identified: (i) work will be suspended in the near vicinity of the occurrence; (ii) the area will be flagged to prevent other construction traffic from entering the location; and (iii) an investigation of the area will be performed and remediation of the feature will be conducted, as appropriate, in accordance with the general procedures described herein and the more detailed procedures that will be given in the construction specifications.

2.3 CHARACTERIZATION OF COVER-COLLAPSE FEATURES AND SOFT SPOTS

If a cover-collapse feature or soft spot is identified, work will cease in the immediate vicinity of the feature/area until it can be investigated and delineated. The investigation will be directed by GPC/SCS based on the recommendations of the CQA Consultant. The investigation may involve:

- Cordon off the area to prevent unauthorized personnel from entering it and record the location using the Global Positioning System (GPS) or other approved means.
- Delineate the horizontal extent of the feature/area.
- Carefully probe the feature/area to estimate and categorize the size (small vs. large) of the affected zone. If the affected zone is estimated to be greater than approximately 5 cubic yards, it will be classified as large; otherwise, it will be classified as small.
- An attempt will be made to establish the depth to the bottom of the feature or soft zone.
- The applicable remediation procedures, selected based on the size of the affected zone as described in subsequent sections, will be implemented.

2.4 REMEDIATION PROCEDURES FOR COVER-COLLAPSE FEATURES

2.4.1 OVERVIEW

The following remediation procedures will be used for small to large cover-collapse features. These remediation procedures will be tailored or modified to account for the field conditions observed. Three options are provided below for general guidance. In cases where the cover-collapse feature investigation results in an excavation extending below the water table, dewatering or ground improvement techniques may be used to stabilize the bottom of the excavation prior to proceeding with the remediation procedure.

2.4.2 Option 1 – Graded Rock Filter

A graded rock filter will be used for the remediation of relatively small cover-collapse features, as directed by GPC/SCS based on recommendations of the CQA Consultant. This procedure involves using successively smaller gradations of stone to fill the cover-collapse feature throat (i.e., zone in which the soil has raveled downward to form the surface depression), as shown on Figure 1 and described below:

- *Layer 1* – Carefully clean out the feature to the extent practicable and then place shot rock fill into the throat of the cover-collapse feature to block it and prevent further loss of materials.
- *Layer 2* – Place a layer of smaller-sized graded rock to fill the voids in the shot rock and provide a transition layer.
- *Layer 3* – Place a layer of crusher run over Layer 2 before proceeding to backfilling with soil.

The backfill above Layer 3 will utilize suitable soil fill placed in lifts until the desired elevation is reached where compacted structural fill placement can commence.

2.4.3 Option 2 – Soil/Geotextile Plug

A soil/geotextile plug will be used for the remediation of relatively large cover-collapse features, as directed by GPC/SCS based on recommendations of the CQA Consultant. This procedure involves using successively smaller gradations of stone along with a soil/geotextile plug to block the cover-collapse feature throat, as shown on Figure 2 and described below:

- *Layer 1* – Carefully clean out the feature to the extent practicable and then place shot rock fill into the throat of the cover-collapse feature to block it and prevent further loss of materials.
- *Layer 2* – Place a layer of smaller-sized graded rock to fill the voids in the shot rock. The thickness of this layer will be sufficient to cover the shot rock and create a level working area.
- *Layer 3* – Bench out the area and place a layer of geotextile extending at least 2 feet beyond the footprint of the rock. The Design Engineer may also specify that a layer of geogrid reinforcement (or other reinforcing material) be placed above the geotextile.
- *Layer 4 and subsequent layers* – begin placing and compacting lifts of suitable fill material until the desired elevation is reached where compacted structural fill placement can commence. Compact the fill lifts using smooth-drum rollers or hand-operated compaction equipment to the required moisture/density conditions.

2.4.4 Option 3 – Fill Grouting

Fill grouting may be used in lieu of Options 1 and 2 for the remediation of small to large cover-collapse features, as directed by GPC/SCS based on the recommendations of the CQA Consultant. This procedure involves filling the identified void using flowable fill (i.e., grout) as follows:

- Carefully clean out the feature to the extent practicable.
- Place a tremie pipe or other Design Engineer-approved delivery system into the void. Pump flowable fill into the void to plug the area. If the void does not readily plug, cease pumping for 24 hours and allow fill to set. Repeat the process until void is plugged.

2.5 EXCAVATION AND BACKFILLING AROUND ROCK PINNACLES

Rock pinnacles may be encountered during excavation. Any rock pinnacles encountered at or above the excavation depth should be removed to an elevation approximately 2 feet below the bottom of the excavation, to the extent practicable.

If for some reason a rock pinnacle needs to be left in place, flowable fill will be used to fill in the annulus between the rock pinnacle and competent fill.

2.6 SOFT SPOTS

If an area of generally soft material (as distinct from a cover-collapse feature) is encountered at the bottom of the excavation, a probe-rod and/or proof-rolling will be used to identify the limits of the area. Depending on the size of the area and the conditions encountered in the field, different ground improvement techniques may be used. Three options are provided below for general guidance.

- Excavate the area as needed to remove the unstable materials to the extent practicable. If firm subgrade cannot be found, use a geotextile layer or other suitable ground improvement technique to stabilize the bottom of the excavation and then backfill using suitable soil fill, placed in lifts, until the desired elevation is reached.
- Use fill grout to fill the excavated area.
- Implement shallow soil mixing methods to mechanically mix the in-situ soft material with a stabilizing agent such as cement to improve and stabilize the area.

2.7 PLACEMENT OF COMPACTED FILL

Placement of compacted fill will proceed only after the cover-collapse feature, or area of soft soil has been investigated and improved in accordance with the guidance described in Sections 2.1 through 2.6, and after the acceptance of the improvements by CQA personnel. Compacted fill will be placed and compacted in accordance with the Design Documents.

3. DOCUMENTATION

The foundation improvement engineering methods will be observed by the CQA Consultant and reported in a Daily Field Report, which will be summarized in monthly reports. At a minimum, the monthly report will indicate, for the reporting period, areas where cover-collapse feature investigation and remediation efforts were conducted, the results of the investigations, any field and/or laboratory testing conducted, any remediation activities conducted, and finally the CQA documentation for those activities.

4. REFERENCES

Sowers, G.F. Building on Sinkholes, Design and Construction of Foundations in Karst Terrains, ASCE Press, 1996.

FIGURES

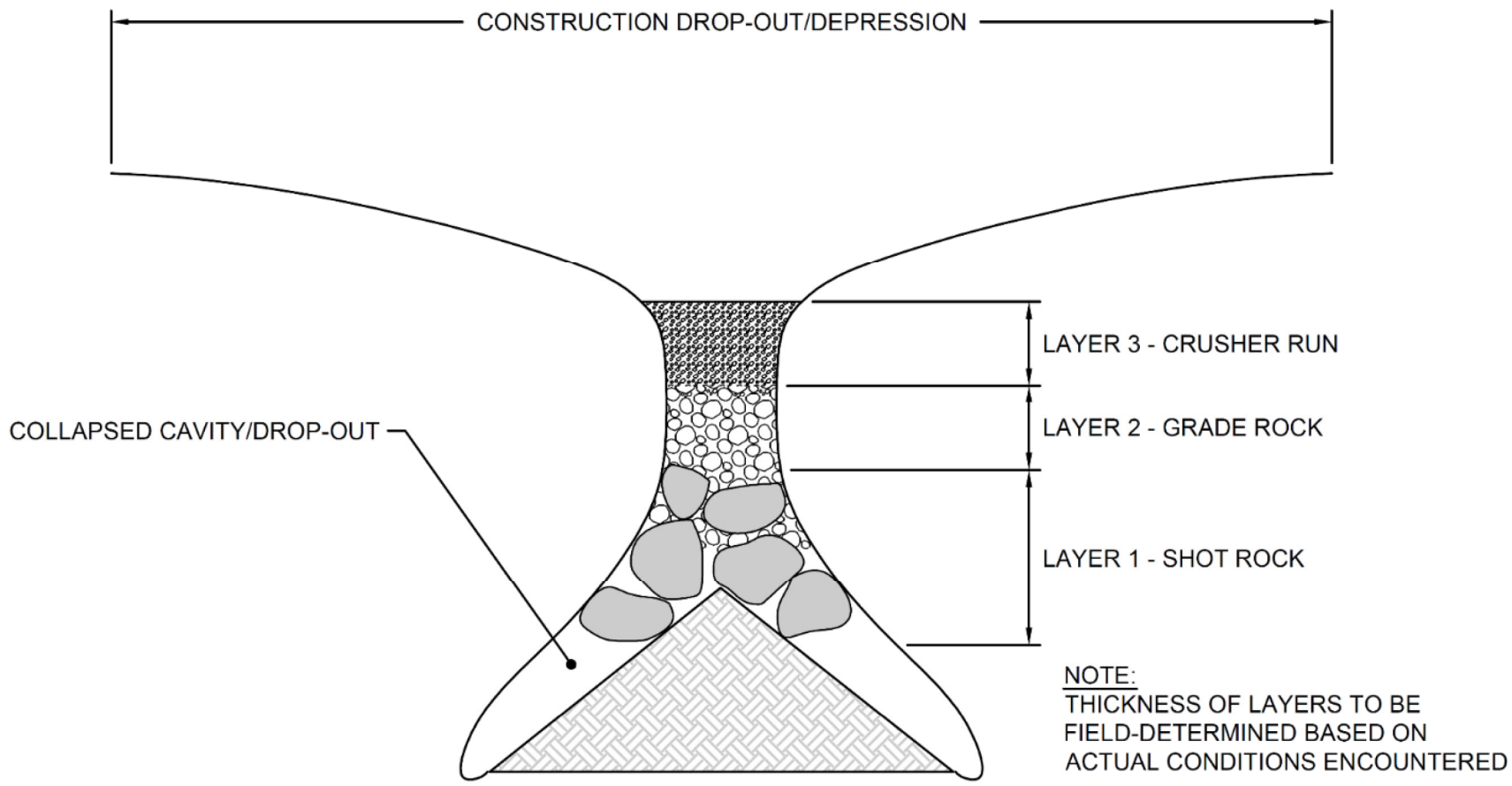

Figure 1. Small Cover-Collapse Feature Remediation using Graded Rock Fill

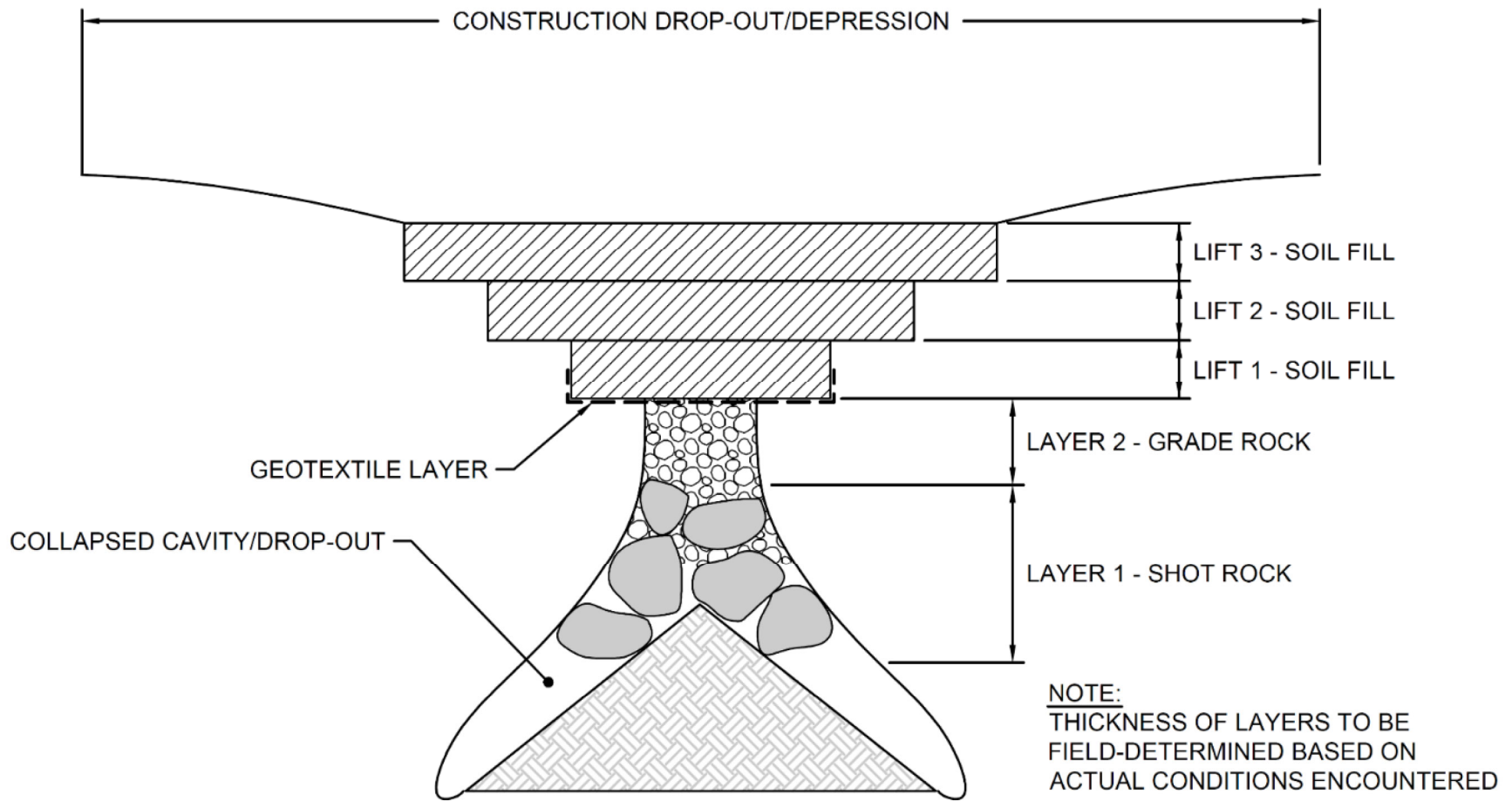

Figure 2. Large Cover-Collapse Feature Remediation using Soil/Geotextile Plug