

# Georgia Department of Natural Resources

Environmental Protection Division  
Agricultural Permitting Unit  
531 Main Street, Suite D  
Tifton, GA 31794-4898  
229-391-2400

## LOW FLOW PROTECTION PLAN GUIDE

### Why is a low flow plan necessary?

Irrigation normally occurs during warm, dry months of the year when stream levels are lower than normal and can result in rapid depletion of the stream or river flow. The Environmental Protection Division (EPD) is charged with regulating the state's water resources. Where necessary, EPD maintains in waters of the state a minimum flow equal to the 7Q10 or the natural flow, whichever is less. The 7Q10 is defined as the minimum average flow for 7 consecutive days that occurs on average once every ten years.

EPD requires all applicants to develop the low flow plan to protect the 7Q10 or the natural flow, whichever is less. If prior permitted withdrawals exist downstream, EPD will require the applicant to develop the low flow plan to protect the Non-Depletable Flow (NDF) or the natural streamflow, whichever is less. The NDF is equal to the 7Q10 plus the calculated amount required to protect prior users.

EPD requires storage as a condition of permit issuance for most non-ag Surface Water Withdrawal Permits. Storage increases the reliability of stream/river withdrawals and protects the source from over-pumping. With storage available, the irrigator can pump from the stream or river in higher flow conditions and from storage during low flow events. EPD encourages all farm irrigation facilities to develop storage when possible.

### How do you develop a low flow plan?

First, select a method for estimating stream discharge. There are three common methods for measuring flow in a stream below a proposed withdrawal site: 1) Calculation of stream discharge by estimating the area of the cross-section and average velocity of the stream; 2) Weir notch; and 3) Parshall flume. The applicant can determine average stream discharge by use of a commercially available flow meter or by using one of the methods described in the attachment.

The following describes method 1. (Please refer to the attachment starting with Section D-1):

#### 1. Locate an appropriate cross-section (for measuring average cross-sectional area)

Select a site with a straight, uniform cross section (free of big rocks, tree roots, deep holes or anything that would make streamflow determination difficult). The cross section should be upstream of the proposed intake location and of reasonable width (a very wide, turbulent stream or river could make stream flow estimation impossible without the installation of a permanent U.S. Geological Survey stage discharge station).

2. Determine the average velocity in the stream at the chosen cross-section.

Select a straight run lengthwise in the stream and determine the average velocity in the stream (See attachment).

3. Determine the area of the chosen cross-section

At the cross-section make several depth measurements to determine an average stream depth. Multiply this average depth by the cross-section width to get the area. (See attachment).

4. Determine stream discharge at the chosen cross-section area

Multiply the estimated stream cross-section area by the estimated average stream velocity.

5. Develop a stream stage-discharge relationship

Upstream of the proposed withdrawal site place a staff of wood, metal or other sturdy material in the most stable part of the stream for use as a stream depth gage. Mark the actual stream depth on the downstream side of the staff gage with a numbered metal tag or similar device. Record this depth in a log along with the corresponding estimated average discharge. Determine and record the depth and average discharge values for different flow conditions.

Plot the staff discharge curve from the recorded data and extrapolate the curve if necessary to get the depth corresponding to the protected low flow. Mark the staff gage at the low flow depth to indicate when pumping must stop.

6. Check the monitoring system periodically

Under low flow conditions estimate and record stream discharge at least once a week using the methods above. Repeat the procedure as often as necessary after high flows and during severe droughts to further refine the staff gage-stream discharge curve.

Before each growing season and after every flood or very heavy rain, check both the staff gage for damage/dislocation and the stream cross section for debris buildup and/or scouring. If necessary repair the cross-section or pick a new one, start over and develop a new staff gage-discharge relationship and curve.

The Permittee should read the staff gage and estimate stream flow discharge twice a week during dry periods when irrigating. During normal or slightly below average flows the Permittee should, on a monthly basis, read the staff gage and determine discharge.

## D. How Much Water is Available

Now that you have learned how much water you will need and you have selected a source, you should determine if you can depend upon the source to supply enough water.

Where the source of water may be limited, such as in small streams, ponds, small lakes and wells, it may be necessary for you to measure the amount of water available.

In areas where stream flow is replenished by mountain snow, the amount of stream flow to be expected during the spring thaw is predicted daily for you by government agencies. The rainfall equivalent of the snow is computed from a measurement of the snow depth and density (Figure 32).

A new development in snow measurement is a system called Snotel (snow telemetry) which measures snow water automatically by use of snow pillows. Information is sent on request from remote data sites by VHF radio signals that are reflected off short-lived meteorite trails in the vapor atmosphere.

By having this information on a daily basis, the water user receives more accurate estimates of expected water supply.

How to determine how much water is available from a source is explained under the following headings:

1. Effect of the Flow of Water in a Stream.
2. Effect of the Amount of Water in a Lake, Pond or Reservoir.
3. Effect of the Flow of Water from a Well.
4. Effect of the Capacity of a Combination of Sources.

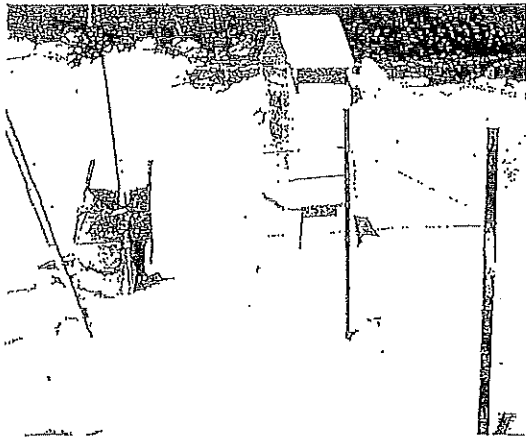

FIGURE 32. Automatic recorder for determining the rainfall equivalent of snow.

### 1. EFFECT OF THE FLOW OF WATER IN A STREAM

If you plan to irrigate from a stream, the U. S. Geological Survey or some other government agency may have already measured the flow. If so, they can tell you how much water to expect from it. If it has not been determined, you should measure the flow during a prolonged dry period, if possible.

Three methods for determining the flow of water in streams are (a) by multiplying the average speed of the stream flow by the cross-sectional areas (Figures 33 and 34), (b) a Weir notch (Figure 35), and (c) a Parshall flume (Figure 36).

a. If you determine the flow of your stream by multiplying the average speed times the cross-sectional area, proceed as follows:

1. Determine the cross-sectional area of the stream (Figure 33).

- (1) Select a straight run in the stream
- (2) Make several measurements of the depth of a cross-section to get an average depth.
- (3) Measure the width of the stream.  
If the width is not uniform for the run, take several readings and determine the average width.

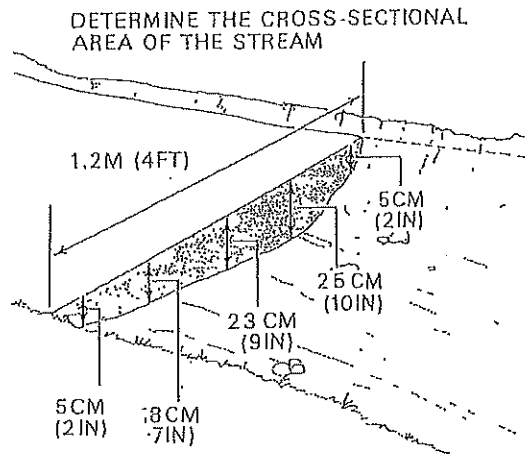

FIGURE 33. Measurements to be made for determining the cross-sectional area of a stream.

Page 3

Where can you get help to develop a successful low flow plan?

You can enlist the services of a qualified civil engineer or hydrologist or contact your County Extension Agent or District Conservationist from the Natural Resources Conservation Service (NRCS) for help. Also, please call our office if you have any questions.

September 1, 1999

S:\WR\AGIS\WCONC\LOWFLOW\LOWFLOW.799

# Stream Flow:

## Flow Speaks Volumes

### Why are we concerned?

Stream flow, or *discharge*, is the volume of water moving past a cross-section of a stream over a set period of time. It is usually measured in cubic feet per second (cfs). Stream flow is affected by the amount of water within a *watershed*, increasing with rainstorms or snowmelt, and decreasing during dry periods. Flow is also important because it defines the shape, size and course of the stream. It is integral not only to water quality, but also to habitat. Food sources, spawning areas and migration paths of fish and other wildlife are all affected and defined by stream flow and velocity. Velocity and flow together determine the kinds of organisms that can live in the stream (some need fast-flowing areas; others need quiet, low-velocity pools). Different kinds of vegetation require different flows and velocities, too.

Stream flow is affected by both forces of nature and by humans. (continued on page 2)

#### Time Needed: Equipment Needed:

30 minutes

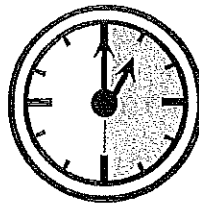

- Tape Measure
- Yardstick or marked D-frame net pole
- Surveying flags/flagging
- Float (an orange works best)
- Net (Can use D-frame net to catch the float)
- Stopwatch or digital watch
- Calculator
- Form to record data
- Pencil
- Hip boots or waders
- String (optional)
- Stakes (optional)

#### DEFINITION OF TERMS

*Discharge:* Another term for stream flow, or the volume of water moving past a designated point over a set period of time.

*Flow Regime:* The pattern of stream flow over time, including increases with stormwater runoff inputs and decreases to a base-flow level during dry periods.

*Impervious Surface:* A surface that does not allow water (e.g., rain) to pass through (infiltrate).

*Rating Curve:* A graphical representation of the relationship between the stage height and the discharge (flow).

*Run:* An area of a stream that has swift water flow and is slightly deeper than a riffle (a run will be about knee/thigh deep).

*Stage Height:* Height of the water in a stream above a baseline.

*Watershed:* An area of land that drains to a main water body.

In undeveloped watersheds, soil type, vegetation, and slope all play a role in how fast and how much water reaches a stream. In watersheds with high human impacts, water flow might be depleted by withdrawals for irrigation, domestic or industrial purposes. Dams used for electric power generation may affect flow, particularly during periods of peak need when stream flow is held back and later released in a surge. Drastically altering landscapes in a watershed, such as with development, can also

change *flow regimes*, causing faster runoff with storm events and higher peak flows due to increased areas of *impervious surface*. These altered flows can negatively affect an entire ecosystem by upsetting habitats and organisms dependent on natural flow rates.

Tracking stream flow measurements over a period of time can give us baseline information about the stream's natural flow rate.

## Safety considerations

You will need to enter the stream channel to make width and depth measurements and to calculate velocity. Be aware of stream velocity, water depth, and bottom conditions at your stream-monitoring site. Do not attempt to measure stream flow if water velocity appears to be fast enough to knock you down when you are working in the stream. If you are unsure of water depth across the width of the stream, be sure to proceed with caution as you move across the stream, or choose an alternate point from which to measure stream flow.

## Determining Stream Flow (Area x Velocity = Flow)

The method you are going to use in determining stream flow is known as a velocity-area approach. The task is to find out the volume of water in a 20-ft. (at least) section of stream by determining both the stream's velocity and the area of the stream section. You will first measure the width of the stream, and then measure water depth at a number of locations across the width to find the average depth at your monitoring site. Then by multiplying the average depth by the width, you can determine the average cross-sectional area (ft<sup>2</sup>) of the stream. Water velocity (ft/sec) is determined simply by measuring the number of seconds it takes a float to travel along the length of stream you are studying. Since water velocity varies at different depths, (surface water moves more quickly than subsurface water because water moving against rough bottom surfaces is slowed down by friction) you will need to multiply velocity by a correction factor to adjust your measurement to account for the effect of friction. The actual equation you will use to determine flow is this: Flow=Area x Corrected Velocity. This method was developed and adapted from several sources (see bibliography). Alternative methods that may be better for your monitoring site are featured in the sidebar below.



### Stream Flow Monitoring Methods: Professional and Home-Made

The type of monitoring station used by professionals depends on the conditions at the site including size, slope, accessibility, and sedimentation of the stream. Flow can also be measured at spillways, dams, and culverts or by using a weir or flume, which are man-made structures within a stream that provide a fixed stage-flow relation. Another method, using a home-made combination staff/crest gage, allows volunteer monitors to measure the water level (stage) both at the time of inspection and at the highest level reached since last inspected. This tool is made of PVC pipe, granulated cork and other materials. For more information, including how to make your own, visit:

[www.epa.gov/owow/monitoring/volunteer/newsletter/volmon07no2.pdf](http://www.epa.gov/owow/monitoring/volunteer/newsletter/volmon07no2.pdf)

# Measuring and Calculating Stream Flow

## Site location

1. At your monitoring site, locate a straight section of stream that is at least 20 feet in length and has a uniform width. The water should be at least 6 inches deep, and have some movement. Unobstructed runs or riffles are ideal sites to choose.
2. Measure 20 feet along the length of your chosen stream segment with your measuring tape and mark both the up and downstream ends of the section with flagging.

## Width and depth measurements

3. Working with a partner, measure stream width (wetted edge to wetted edge) by extending a measuring tape across the stream at the midway point of your marked stream segment. Record the width in feet on your recording form. (A tape measure graduated in tenths of feet will make calculations easier.)

4. Secure the measuring tape to both shores so that the tape is taut and above the surface of the water. You might choose to attach the tape or a length of string to two stakes secured on opposite banks to create a transect line across the stream if it is impractical to secure the tape using shoreline vegetation. (Figure 1)

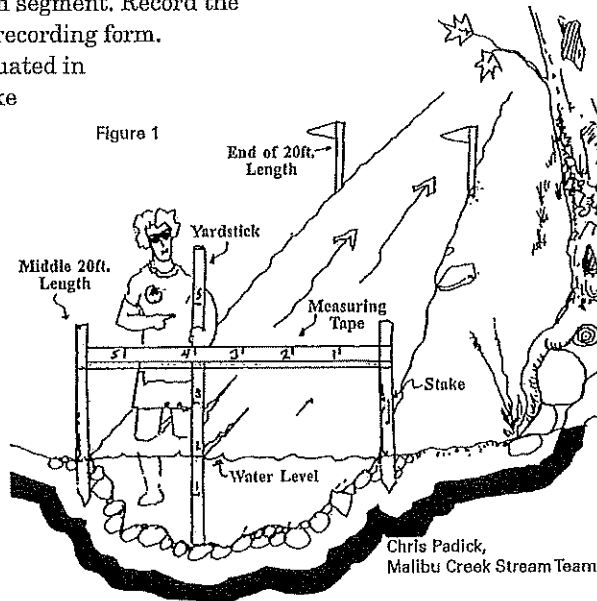

foot length of stream. You will time the floating object (in seconds) a total of four times, at different locations across the stream. Repeating your measurements across the stream, in both slower and faster areas, will help to ensure the closest approximation to the stream's true velocity. This in turn will make your flow calculations more accurate. However, be sure your float travels freely downstream (during every float trial) without catching in slack water areas of the stream. For narrower streams (less than 10 feet), you can conduct only three float trials to assess velocity.

6. Position the person who will release the float upstream from the upper flag. Position the timekeeper on the stream bank (or out of the main flow path) at the downstream flag with the stopwatch. Position the person who will catch the float downstream from the timekeeper (Note: Unless velocity is very fast, the timekeeper should be able to catch the float with a net after they have finished timing its run down the stream).

7. The float-releaser will gently drop the float into the stream a few feet upstream from the upper flag, and will alert the timekeeper to begin timing as the float passes the upstream flag (the

float should have time to get up

to speed by the time it passes the upper flag into the marked length of stream). If the float gets stuck on a log, rock or other obstruction, it should be released from the starting point again.

8. The timekeeper should stop the stopwatch as the float passes the downstream flag and retrieve the float using the net.
9. Record the float time for the first trial on the recording form.
10. Repeat steps 7-9 for each of the remaining float time trials in different sections of the stream. Record the float time (seconds) for each trial on the recording form.

## Velocity measurement

Velocity will be measured by tracking the time it takes a floating object to move the marked 20-

## Calculating stream flow

11. To determine the average depth at the site, first find the sum of your depth measurements. Then divide the sum of the depths by the number of depth measurements (intervals) you made. Record the average depth (ft) in the appropriate location on your recording form.
12. Next, multiply your average depth by the stream width. This is the average cross-sectional area (ft<sup>2</sup>) of the stream. Record this in the appropriate box on your recording form.
13. Determine the average float time by first determining the sum of float times measured. Then divide the sum of the times by the number of float time measurements taken. Record this average float time (seconds) on your recording form.
14. Divide the length of your stream segment (e.g., 20 feet) by the average float time (seconds) to determine the average surface velocity at the site. Record the average surface velocity (ft/sec) on your recording form.
15. Determine the correction factor below that best describes the bottom of your stream and multiply it by the average velocity measurement to account for the effects of friction with the stream bottom on water velocity. Record your corrected average surface velocity on your recording form.
  - a. Correction factor for rough, loose rocks, coarse gravel or weeds: 0.8
  - b. Correction factor for smooth mud, sand, or bedrock: 0.9
16. Multiply the average cross-sectional area (ft<sup>2</sup>) by the corrected average surface velocity (ft/sec) to determine stream flow. Record stream flow (ft<sup>3</sup>/sec or cfs) in the space provided on your recording form.

### Bibliography:

We reviewed and adapted information and methods from Missouri Stream Team Program, the WI DNR, the EPA Volunteer Stream Monitoring Methods Manual (EPA 841-B-97-003), the Nohr Network of Monitors, the Washington Co. (WI) Waterways Program, Hoosier Riverwatch, Project SEARCH, and California's Nonpoint Source Pollution Control Program as well as other technical information.

©2006 University of Wisconsin. This publication is part of a seven-series set, "Water Action Volunteers-Volunteer Monitoring Factsheet Series" and is available from the Water Action Volunteers Coordinator at 608/264-8948.

Water Action Volunteers is a cooperative program between the University of Wisconsin-Extension and the Wisconsin Department of Natural Resources. For more information, contact the Water Action Volunteers Coordinator at 608/264-8948.

## What is a Staff Gage?

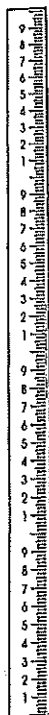

A staff gage is a tool that is often used in conjunction with other methods to determine stream flow. It looks like a large ruler placed vertically within a stream in a position least likely to catch floating debris, and that will be stable during high water flows and the winter freeze. Staff gages are calibrated in tenths of feet and allow a monitor to read and record the stage height (the height of water in the stream at a certain level) any time a monitor has the opportunity to visit the stream site. Staff gages are often placed at the stream's edge on a bridge abutment. WAV monitors may choose to place a staff gage at their monitoring site. You may need a permit to do this, however. Contact your local DNR Service Center for more information on permits.

If a staff gage is installed, monitors can simply record the water level on the staff gage without measuring flow. This method will provide added detail when assessing other parameters. However, scores cannot be compared between sites because each reading is germane only to that site.

Monitors may also choose to install a staff gage at their monitoring site and then, at a number of different water levels, record the stage height and determine the flow in the stream by following methods provided in this fact sheet. This type of monitoring is similar to what professionals do to determine a *rating curve* for a stream discharge monitoring station. The rating curve will reveal the stream's unique relationship between flow and stage height. Eventually, a monitor could determine stream flow simply by reading the stage height on the staff gage and looking at the site's rating curve to see what the flow is at that stage height. Caution must be used with this method since weeds, ice, or other factors can cause ponding of the stream water or movement of the staff gage over time, thus affecting rating curve results.

UW  
Extension

