

# **Seventeen Mile River Dissolved Oxygen TMDLs**

## **Satilla River Basin (HUC 03070201)**

**Submitted to:**

**U.S. Environmental Protection Agency  
Region 4  
Atlanta, Georgia**

**Submitted by:**

**Georgia Department of Natural Resources  
Environmental Protection Division  
Atlanta, Georgia**

**June 2002**

## Table of Contents

Section	Title	Page
	TMDL Executive Summary .....	3
1.0	Introduction .....	5
2.0	Problem Understanding .....	6
3.0	Water Quality Standards.....	10
4.0	Source Assessment .....	11
5.0	Summary of the Technical Approach .....	13
6.0	Loading Capacity.....	24
7.0	Waste Load and Load Allocations.....	26
8.0	Margin of Safety .....	27
9.0	Seasonal Variation.....	28
10.0	Monitoring Plan.....	28
11.0	Point and Nonpoint Source Approaches.....	28
12.0	Public Participation.....	28
13.0	References.....	29
	Appendix A - Data Used in TMDL Analysis .....	31

## TMDL Executive Summary

**Basin Name:**                    **Seventeen Mile River Watershed in the Satilla River Basin (HUC 03070201)**

**Table 1: Dissolved Oxygen Impaired Segments on 2000-303(d) List.**

Segment Name	Priority Ranking	Use Classification	Size (miles)	Location
Seventeen Mile River (upstream)	2	Fishing	7	Twenty Mile Cr. N. of Douglas to Otter Cr. Downstream Gen. Coffee State Park (Coffee Co.)
Seventeen Mile River (downstream)	2	Fishing	13	Twentynine Mile Cr. To Satilla River (Coffee Co.)

### **Summary of TMDL Analysis and the TMDL for the Listed Segment**

The TMDL analysis included an evaluation of the relationship between the sources and the impact on the receiving water. Due to the many factors that dynamically influence in-stream dissolved oxygen concentrations, this relationship was developed using a complex model linkage. The impaired waterbody was modeled using both a dynamic receiving water model and a dynamic watershed model. The linkage of these models permitted representation of major processes associated with dissolved oxygen concentration variability. By developing a linked watershed-receiving water model, the impacts of various factors (including all nonpoint and point source loads) on in-stream dissolved oxygen were evaluated. Ultimately, the loading capacity of the waterbody for each critical pollutant affecting the dissolved oxygen concentration was determined. The required source-based loading reduction required to meet the in-stream standard was also calculated.

This approach permitted assessment of point source and nonpoint source contributions (including both watershed and leaf litterfall).

### **Applicable Water Quality Standards**

The applicable dissolved oxygen water quality criteria for Seventeen Mile River in the Satilla River Basin are as follows:

Numeric - GAEPD. A daily average of 5.0 mg/L and no less than 4.0 mg/L at all times for waters supporting warm water species of fish. 391-3-6-.03 (c) (1). (GAEPD, 2000)

Natural Water Quality – GAEPD. It is recognized that certain natural waters of the State may have a quality that will not be within the general or specific requirements contained herein. This is especially the case for the criteria for dissolved oxygen, temperature, pH and fecal coliform. NPDES permits and best management practices will be the primary mechanisms for ensuring that the discharges will not create a harmful situation. 391-3-6-.03 (7). (GAEPD, 2000)

Natural Water Quality – EPA. Where natural conditions alone create dissolved oxygen concentrations less than 110 percent of the applicable criteria means or minima or both, the minimum acceptable concentration is 90 percent of the natural concentration. (USEPA, 1986).

Due to naturally occurring low dissolved oxygen in the impaired segment, the EPA natural water quality standard was appropriate to support the proposed allocations. That is, if a model result showed a natural dissolved oxygen less than 5.0 mg/L, the natural model result would define the DO standard to be applied. In this case, the standard would become 90 percent of the computed natural DO.

**Technical Approach**

- Models Applied: Hydrologic Simulation Program Fortran (HSPF) and the Environmental Fluids Dynamic Computer Code (EFDC).
- Calibration Data: USGS field data from June-July, 1998.
- Calibration Conditions: (1) USGS flows measured in June-July, 1998.  
(2) USGS Temperatures measured in June-July 1998.  
(3) Point source DMR data for June-July, 1998.  
(4) Depths, velocities, kinetic rates, reaeration, and boundary conditions based on 1998 USGS field data and/or GAEPD standard modeling practices.
- Critical Conditions: (1) June-July, 1998 (low flow and high temperature).  
(2) Point source discharges at current permit limits.  
(3) Same depths, velocities, kinetic rates, reaeration, and boundary conditions as calibration conditions.
- Natural Conditions: (1) Same flows as critical conditions.  
(2) Same temperatures as critical conditions.  
(3) All point sources completely removed.  
(4) Same depths, velocities, kinetic rates, reaeration, and boundary conditions as calibration conditions.
- Margin of Safety: Implicit, based on the following conservative assumptions:  
(1) Modeling linked watershed and instream processes.  
(2) Permitted point sources are loaded into model for allocation runs (average monthly permit values).  
(3) Ran model with real flow and temperature during summer instead of 7Q10 and 75% temperature.  
(4) Assumed 41% saturation for upstream DO (Meyer, 1992).
- Seasonality: Dissolved oxygen data predominantly showed impairments during the high-temperature, low-flow conditions (June-July, 1998).
- Monitoring: Follow-up monitoring according to 5-year River Basin Planning cycle (Georgia EPD, 1996).
- Approach: NPDES Permits for point sources; Best management practices for nonpoint sources.
- Date Submitted: Draft - June 2000, Re-proposed - March 2002, Final – June 2002

**Table 2: Summary of TMDLs for Seventeen Mile River.**

Listed Segment	TMDL – TOC (lbs/yr)	TMDL – TN (lbs/yr)	TMDL – TP (lbs/yr)
Seventeen Mile River (upstream)	12,235,204	452,404	117,591
Seventeen Mile River (downstream)	21,939,495	751,265	154,464

## 1.0 Introduction

The State of Georgia is required to develop total maximum daily loads (TMDLs) for waters not meeting water quality standards, in accordance with Section 303(d) of the Clean Water Act and the U. S. Environmental Protection Agency (EPA) Water Quality Planning and Management Regulations (40 CFR Part 130). Water quality data collected in 1998 indicate that a number of waterbodies in the Suwannee River Basin did not achieve water quality standards for dissolved oxygen. The low dissolved oxygen conditions may be due to naturally occurring conditions. These waterbodies were listed on the Georgia 2000-303(d) list. There were 21 TMDLs for dissolved oxygen that were finalized in December 2001, but due to a revision in the point and nonpoint source allocations from the June 2000 draft TMDLs, the Seventeen Mile River TMDLs were re-proposed in this final TMDL report. This document presents the dissolved oxygen TMDLs for Seventeen Mile River in the Satilla River Basin (HUC 03070201). The Satilla River Basin is shown in Figure 1-1.

Four river basins, the Ochlockonee, Suwannee, Satilla, and the St. Marys were the focus of TMDL development in Georgia in 2000. The four river basins are shown in Figure 1-1.

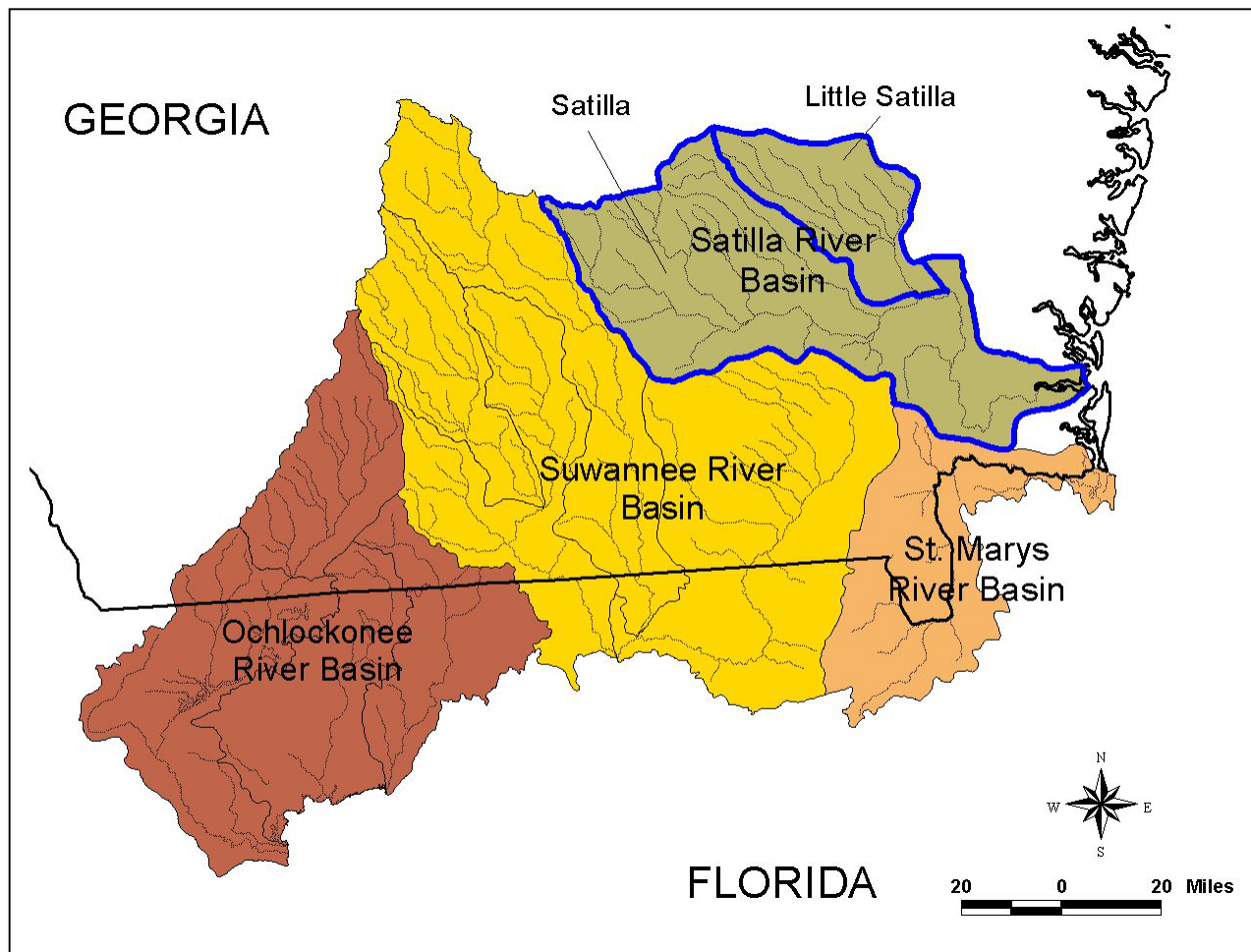

**Figure 1-1. Southern Four Georgia Basins Requiring Dissolved Oxygen TMDL Development (Ochlockonee, Suwannee, Satilla, and St. Marys River Basins).**

## 2.0 Problem Understanding

The Satilla River is the border between Florida and Georgia and its headwaters are located in the Okefenokee Swamp in Georgia. The river basin covers an area of approximately 1,804 mi<sup>2</sup>. Seventeen Mile River is located in the headwaters of the Satilla River Basin (HUC 03070201) near Douglas, Broxton, and Ambrose, GA as shown in Figure 2-1. The Seventeen Mile River watershed is approximately 295 mi<sup>2</sup>. Seventeen Mile River flows into the Satilla River. Figure 2-1 shows the drainage area and relative location of the Seventeen Mile River watershed.

The GAEPD established water quality monitoring stations for the Ochlockonee, Suwannee, Satilla, and St. Marys River Basins as a part of the Georgia River Basin Planning Program (GAEPD, 1996). There were 138 stations established and sampled in the southern Georgia four river basins in 1998. Sixty-nine of the sampling stations were in the Suwannee River Basin. The monitoring work was conducted as a cooperative effort between the GAEPD and the United States Geologic Survey (USGS). The four river basins will be monitored again in 2003. It should be noted that core stations in the four basins are monitored each year. During 1998, the USGS measured gage height, water temperature, pH, and dissolved oxygen on-site and collected water samples for laboratory analyses. The laboratory water quality parameters included turbidity, five-day biochemical oxygen demand (BOD5), ammonia, nitrate-nitrite, total phosphorus, total organic carbon, and fecal coliform. In addition, samples for metals analyses were collected at each station. These data were used to assess compliance with water quality standards and the assessment results were used by the GAEPD in the development of the 2000-303(d) list.

For the 303(d) listing of Seventeen Mile River on the state's 2000 list, the following 2 water quality stations that exhibited dissolved oxygen impairments in 1998:

- USGS 02226341 – Seventeen Mile River at SR32 near Douglas, GA (also GAEPD 07006001)
- USGS 02226356 – Seventeen Mile River at SR64 near Stokesville, GA (also GAEPD 07016601)

The water quality station, the NPDES discharges, populated areas, streams from the USGS National Hydrography Dataset (NHD), and the impaired segment are all shown in Figure 2-2.

The data for both water quality stations are plotted in this section and listed in Appendix A. Figures 2-3 and 2-4 display the dissolved oxygen measurements versus temperature, BOD5, and ammonia for the upstream station near Douglas, GA. Figures 2-5 and 2-6 display the dissolved oxygen measurements versus temperature, BOD5, and ammonia for the downstream station near Stokesville, GA. The dissolved plots show that low flow periods are prevalent during the June through September period. There was not a continuous flow gage in the Seventeen Mile River watershed. During the 1998 monitoring year, due to drought conditions, the USGS did not report a flow measurement for each sampling event.

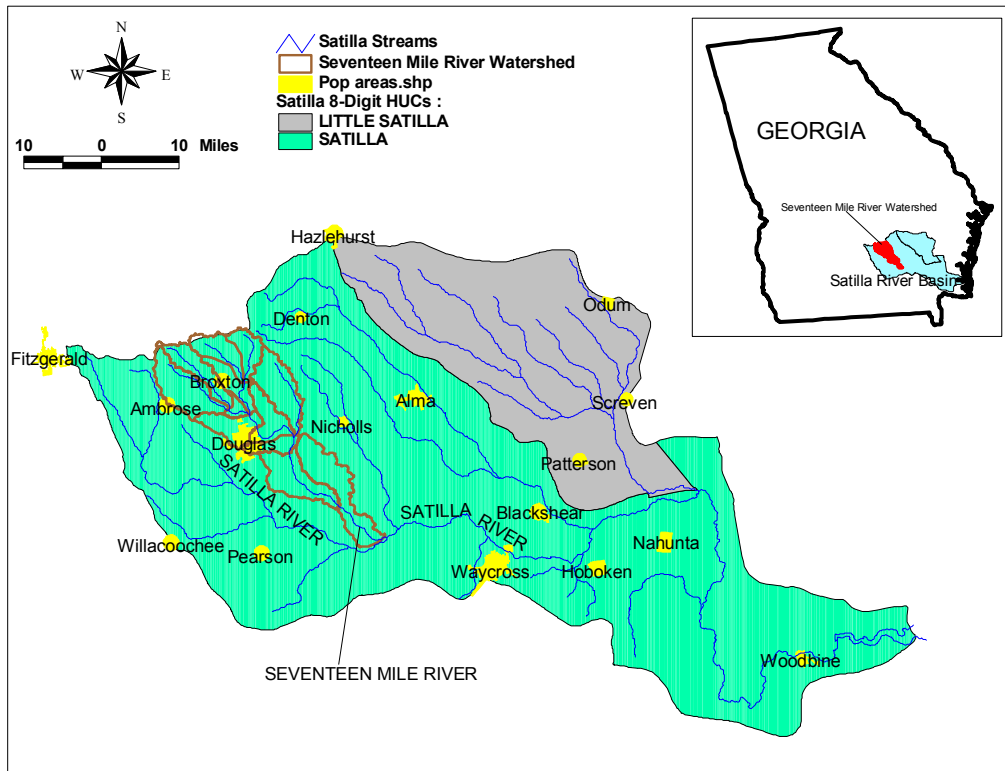

Figure 2-1. Location Map of the Seventeen Mile River Watershed.

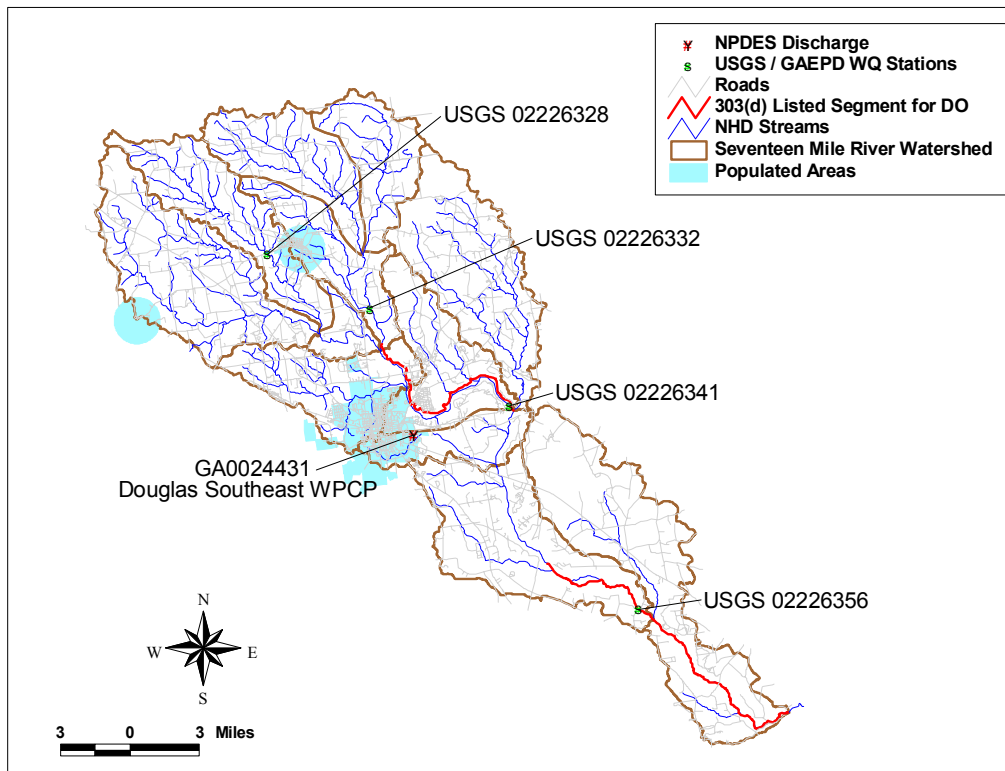
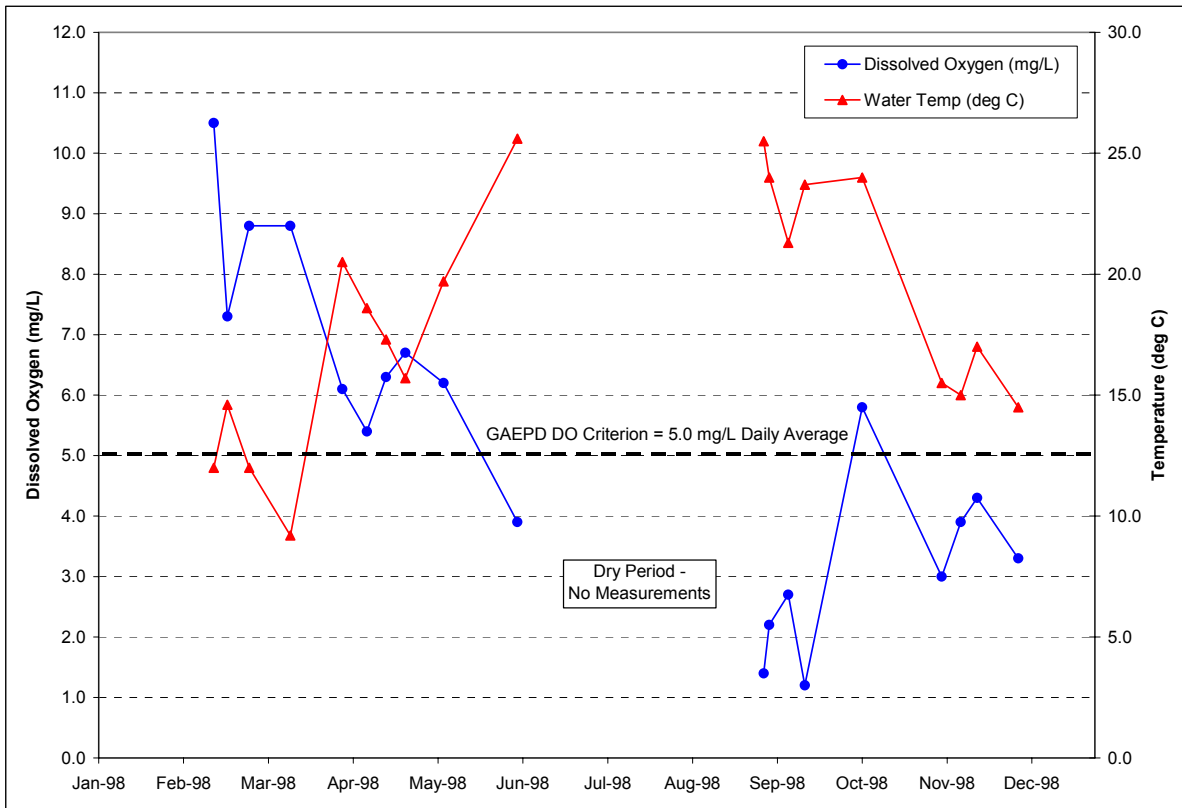
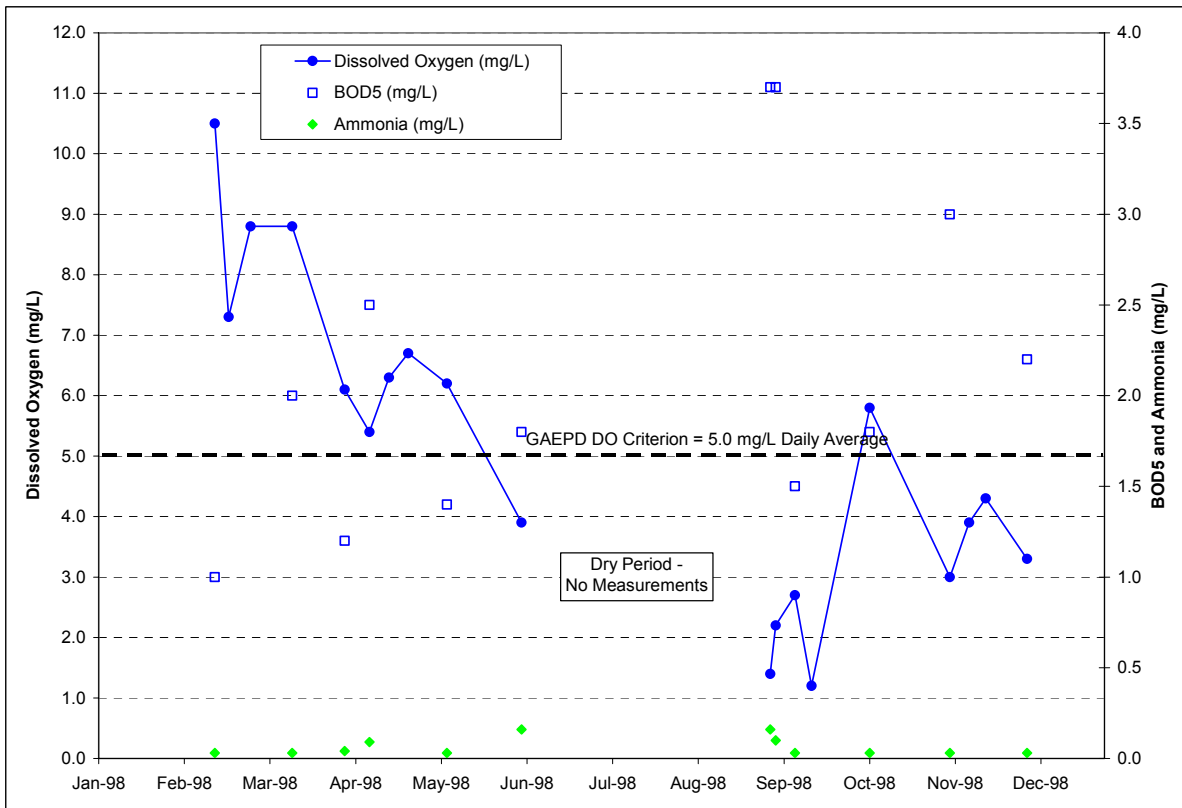

Figure 2-2. 303(d) Listed Segment for Dissolved Oxygen, NPDES Discharges, and Water Quality Stations on Seventeen Mile River.

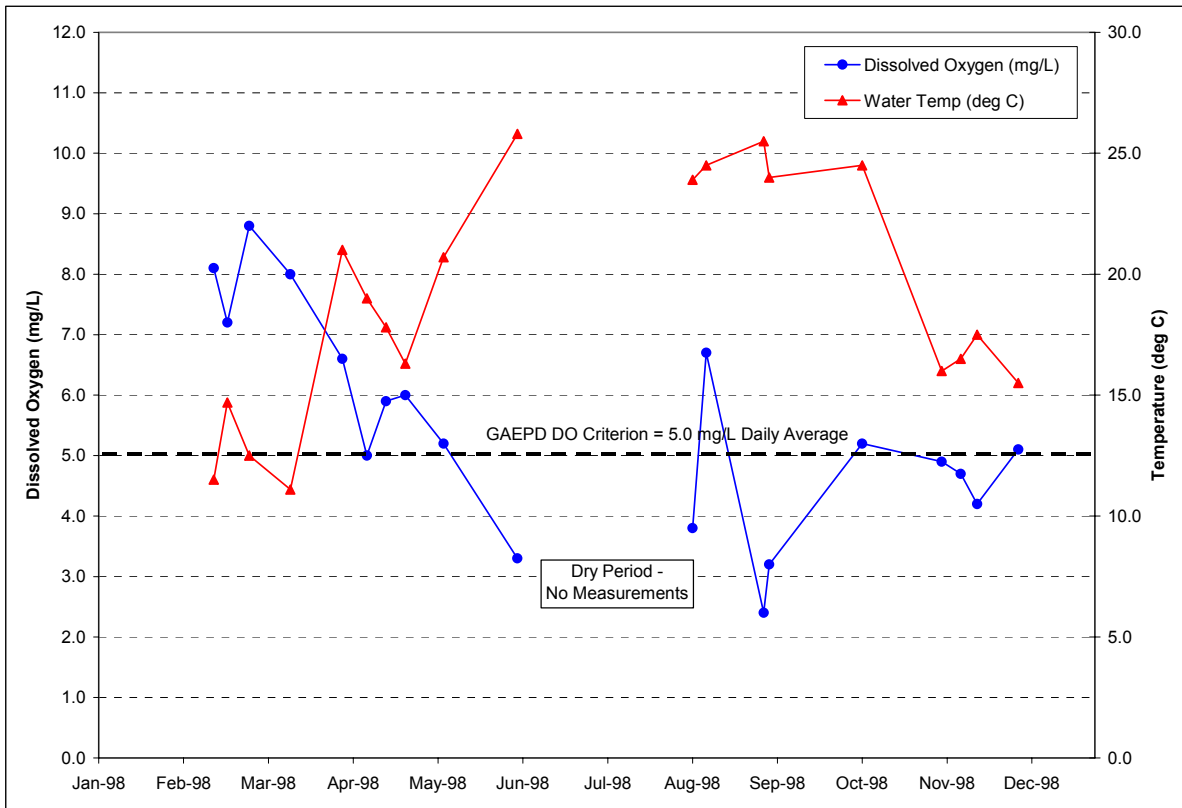

**Figure 2-3. Dissolved Oxygen versus Temperature at USGS 02226341 (GAEPD 07006001) – Seventeen Mile River at SR32 near Douglas, GA.**

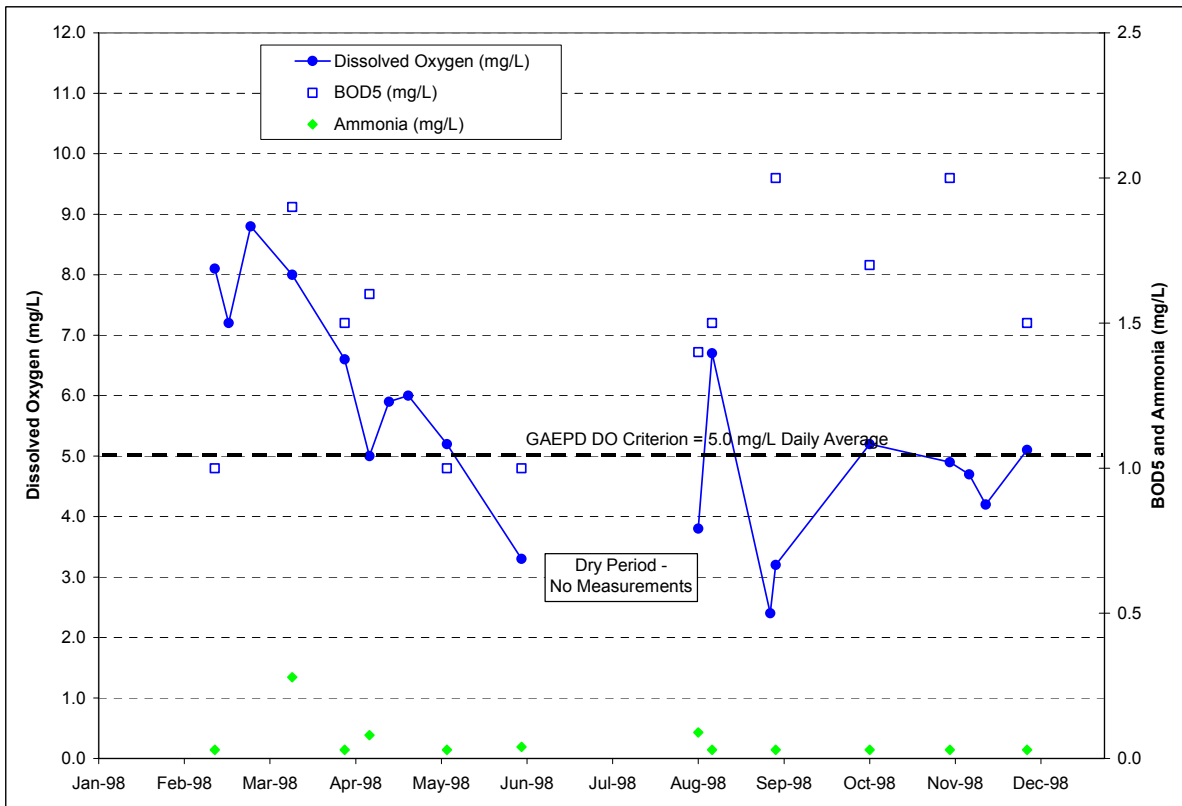

**Figure 2-4. Dissolved Oxygen versus BOD5 and NH3 at USGS 02226341 (GAEPD 07006001) – Seventeen Mile River at SR32 near Douglas, GA.**





**Figure 2-5. Dissolved Oxygen versus Temperature at USGS 02226356 (GAEPD 07016601) – Seventeen Mile River at SR64 near Stokesville, GA.**



**Figure 2-6. Dissolved Oxygen versus Temperature at USGS 02226356 (GAEPD 07016601) – Seventeen Mile River at SR64 near Stokesville, GA.**

### 3.0 Water Quality Standards

Seventeen Mile River is designated by the State of Georgia with a water use classification of fishing. Georgia Water Quality Standards (GAEPD, 2000) have defined water quality criteria for surface waters as those that are used, or have a high potential to be used, for fishing and primary contact recreation. Georgia's water quality standards state the following criteria for measurements of dissolved oxygen with a use classification of fishing:

*Numeric.* A daily average of 5.0 mg/l and no less than 4.0 mg/l at all times for waters supporting warm water species of fish\*. A daily average of 6.0 mg/l and no less than 5.0 mg/l at all times for waters designated as trout streams by the Wildlife Resource Division.

**GAEPD, 2000**

\* Seventeen Mile River is assumed to be classified as supporting warm water species of fish.

Certain waters of the state may have conditions where the dissolved oxygen is naturally lower than the recommended numeric dissolved oxygen criteria and cannot meet the numeric criteria unless reductions in the natural nutrient and carbon loads are obtained. This reduction in the natural forest or wetland contributions is not feasible, practicable or desirable, therefore the EPA Dissolved Oxygen Criteria was instituted and dissolved oxygen target limits were identified for TMDL development. The target limits were identified as 90% of the minimum naturally occurring concentration for impaired waterbodies.

*Natural Water Quality.* “It is recognized that certain natural waters of the State may have a quality that will not be within the general or specific requirements contained herein. This is especially the case for the criteria for dissolved oxygen, temperature, pH and fecal coliform. NPDES permits and best management practices will be the primary mechanisms for ensuring that the discharges will not create a harmful situation.” 391-3-6-.03(7)

**GAEPD, 2000**

U.S. EPA guidelines supplement the Georgia guidelines for naturally low dissolved oxygen conditions by providing numeric targets:

“Where natural conditions alone create dissolved oxygen concentrations less than 110 percent of the applicable criteria means or minima or both, the minimum acceptable concentration is 90 percent of the natural concentration.” Ambient Aquatic Life Water Quality Criteria for Dissolved Oxygen (Freshwater), EPA440/5-86-003, April 1986.

**USEPA, 1986**

A dissolved oxygen violation analysis was performed for water quality station in the Seventeen Mile River watershed basin by comparing observation values to numeric water quality standards. The analysis confirmed that the water quality criterion was violated for the listed segment.

## 4.0 Source Assessment

The 303(d) listing for Seventeen Mile River identified nonpoint sources as the primary contributor to the dissolved oxygen impairment. An examination of permits and land use information for the watershed was used to identify all potential sources of oxygen demanding substances in the basin. These sources (divided into Point and Nonpoint Sources) were considered in the source loading analysis and the subsequent TMDL.

### Point Sources

Potential point sources affecting in-stream dissolved oxygen concentrations include wastewater treatment plants, industrial facilities (e.g., food processing facilities), combined sewer overflows, sanitary sewer overflows, and stormwater runoff. Point sources directly discharge organic and inorganic oxidizable substances into a waterbody, which ultimately affects dissolved oxygen concentrations. Pollutants that are typically monitored by facilities and should be considered in an evaluation of point source effects on in-stream dissolved oxygen concentrations include BOD, NH<sub>3</sub>, and TSS.

The point source contributing to this listed water is GA0024431 – Douglas Southeast WPCP. The facility is located in Coffee County and is approximately 6 miles upstream of the USGS 02226341 water quality station. Figure 2-2 shows its location with respect to the watershed. The permit limits during the 1998 monitoring year for GA0024431 are as follows:

- Flow = 6.0 mgd
- BOD<sub>5</sub> = 12.0 mg/L
- Ammonia = 1.0 mg/L
- Dissolved Oxygen (minimum) = 6.0 mg/L

Total phosphorus was assumed to be 5.0 mg/L since there are no permit limits or DMR data available.

There are 2 other facilities located in the watershed and they are GA0035513 (Dutch Quality Homes) and GA0029751 (CSI). After reviewing the PCS data, it was determined that they do not play a significant role in the dissolved oxygen depletion in Seventeen Mile River and were not included in the analysis.

### Nonpoint Sources

Nonpoint sources of oxygen demanding substances are typically separated into urban and rural components. In urban or suburban settings, important sources of loading are surface storm runoff, failing septic systems, and leakage and overflows from sanitary sewer systems. In rural areas, sources of oxygen demanding substances may include diffuse runoff of agricultural fertilizer and animal wastes (from manure application or grazing animals), erosion of sediments, and runoff from concentrated animal operations.

Based on a land use assessment and review of the literature, nonpoint source contributions from urban, agriculture, and forested areas are all likely in the Seventeen Mile River watershed. Croplands, pasture, forest, urban (or built-up) areas, and wetlands were all identified in the basin.

The land use distribution for the watershed contributing to the impaired segment is displayed in Table 4-1. Figure 4-1 graphically displays the land use distribution within the study area.

**Table 4-1. Land Use for the Seventeen Mile River Watershed.**

Land Use	Acres	Percent of Total
Built-up Impervious	2,828	1%
Built-up Pervious	15,152	8%
Cropland	62,990	33%
Forest	70,246	37%
Pasture	14,752	8%
Wetland	22,804	12%
TOTAL (acres)	188,772	100%

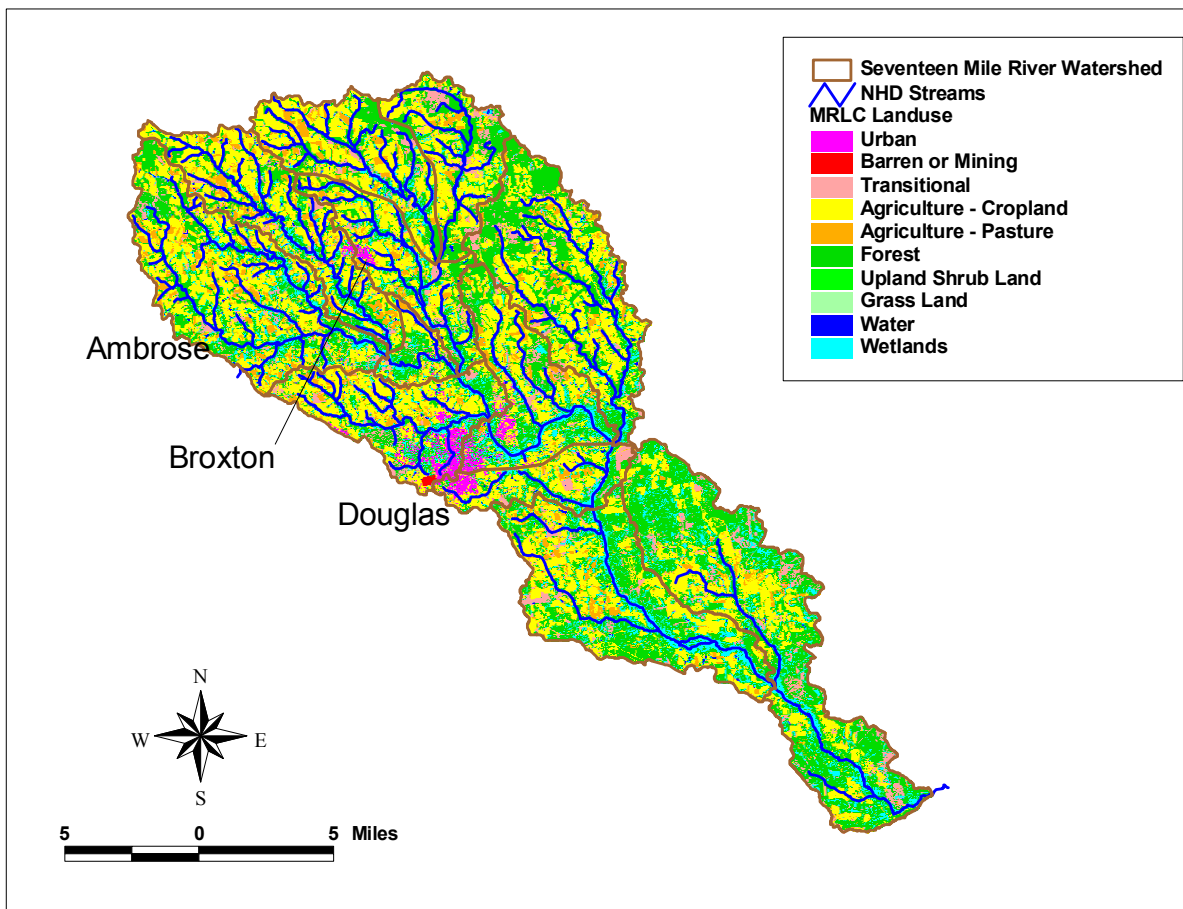

**Figure 4-1. Land Use Representation in the Seventeen Mile River Watershed.**

In addition to the aforementioned nonpoint sources of oxygen demanding substances, many southern Georgia streams receive significant contributions of oxygen demanding organic materials from local wetlands and forested stream corridors. In particular, the following sources of organic materials have been identified:

- adjacent wetland/swampy areas that have organically rich bottom sediments
- direct leaf litterfall onto the water surface from overhanging trees and vegetation
- lateral leaf litterfall that has fallen into the floodplains

Leaf litterfall plays a major role in the amount of carbon in the stream water column. The riparian areas of the watershed are the primary source of litterfall. At higher flows, the leaf litterfall in the floodplains are picked up and transported laterally into the stream. Many streams in southern Georgia are referred to as “blackwater” streams due to the humic substances leached from surrounding watersheds that impart color to the water (Meyer, 1992). Low dissolved oxygen in blackwater streams is common in the summer months when the temperatures are high and the flows are low.

## 5.0 Summary of the Technical Approach

The TMDL analysis includes an evaluation of the relationship between the sources and the impact on the receiving water. Due to the many factors that dynamically influence in-stream dissolved oxygen concentrations, this relationship was developed using a complex model linkage.

Impaired waterbodies were modeled using both a dynamic receiving water model and a dynamic watershed model. The linkage of these models permitted representation of major processes associated with dissolved oxygen concentration variability, including:

- Input and oxidation of carbonaceous waste material
- Input and oxidation of nitrogenous waste material
- Input and oxygen demand of sediments in the water body
- Use of oxygen through aquatic plant respiration
- Reaeration
- Oxygen production through photosynthesis

By developing a linked watershed-receiving water model, the impacts of various factors (including all nonpoint and point source loads) on in-stream dissolved oxygen were evaluated. Ultimately, the loading capacity of the waterbody for each critical pollutant affecting the dissolved oxygen concentration was determined. The required source-based loading reduction required to meet the in-stream standard was also calculated. This approach permitted assessment of point source and nonpoint source contributions (including both watershed and leaf litterfall, etc.).

The technical approach is summarized in the following sections:

- Model selection
- Source representation
- In-stream representation
- Model testing

### Model Selection

The Hydrologic Simulation Program Fortran (HSPF), a dynamic watershed model capable of simulating a wide range of water quality parameters, was selected to represent nonpoint source pollutant contributions (and point source contributions as necessary) to the impaired waterbodies. The impaired waterbodies themselves were modeled using the Environmental Fluid Dynamics Code (EFDC), a 3-D hydrodynamic and water quality model capable of simulating dissolved oxygen and a full suite of dissolved oxygen interactions. Output from the HSPF was applied directly to the EFDC, in order to provide the linkage between source and waterbody response.

## Source Representation

Nonpoint and point sources were both represented in the linked models. The watershed model was primarily implemented to represent upstream nonpoint source contributions to the impaired waterbody. Direct contributions of leaf litter (representation of organic materials contributed by overhanging trees and vegetation) to each impaired waterbody were represented in the receiving water model.

Point sources were represented in both the receiving water model and the watershed model. Facilities discharging within the same 12-digit subwatershed as a modeled impaired waterbody were represented in the receiving water model. Facilities discharging to unimpaired reach segments that affect impaired waterbodies, but were not explicitly modeled with the receiving water model, were represented in the watershed model.

### Nonpoint Source Representation

Nonpoint source pollutants likely to impact dissolved oxygen include nutrients, BOD, and sediment. These pollutants have a direct impact on oxygen reducing procedures, including oxidation of carbonaceous and nitrogenous materials and exertion of oxygen demand by sediments. They also affect oxygen replenishment through plant respiration and photosynthesis production.

The watershed model represents the variability of nonpoint source contributions through dynamic representation of hydrology and land practices. In a number of situations, the watershed model additionally accounts for point source contributions (where point sources are located on major streams contributing to an impaired waterbody that are not represented explicitly in the receiving water model). Key components of the watershed model include:

- Watershed segmentation
- Meteorological data
- Simulation period
- Land use representation
- Hydrologic representation
- Water quality representation

#### *Watershed Segmentation*

In order to evaluate the sources contributing to an impaired waterbody and to represent the spatial variability of these sources within the watershed model, the contributing drainage area was represented by a series of subwatersheds. These subwatersheds were represented using the Georgia 12-digit watershed data layer. In some situations, the 12-digit data layer required further subdivision for appropriate hydrologic connectivity and representation.

#### *Meteorological Data*

Nonpoint source loadings and hydrologic conditions are dependent on weather conditions. Weather

parameters required to simulate various components of hydrology and water quality include precipitation, air temperature, dew point, wind speed, solar radiation, and percent cloud cover. Hourly data from weather stations within the boundaries of or in close proximity to the subwatersheds being modeled, were applied to the watershed model.

The weather station used to represent the hydrology in the Seventeen Mile River watershed was Pearson (GA6879). Examination of the precipitation at this stations shows that the wettest months are typically January, February, March, and July. The driest month is typically October. Monthly and annual patterns are similar for all stations. Appendix A presents rainfall characteristics, including monthly mean and annual total precipitation for the Abbeville station.

#### *Simulation Period*

Selection of an appropriate simulation period is important in nonpoint source modeling due to the variability of hydrologic and source loading conditions over time. The year 1998 was selected as the simulation period. This time period was selected due to its coverage of a wide range of hydrologic conditions, including heavy rainfall and drought conditions. Additionally, this period contained the most extensive monitoring data, which is necessary for model calibration.

The HSPF model was run for 10 years to examine the watershed water quality loading over an extended period of time. The 1998 watershed load was also compared directly to the 1997 loading year to see if there were any anomalies in the loading rates.

#### *Land Use Representation*

The watershed model uses land use data as the basis for representing hydrology and nonpoint source loading. Land use categories for modeling were selected based on the USGS Multi-Resolution Land Classification (MRLC) data set, and included built-up, forest, cropland, pasture, and wetlands. The USGS data represents conditions in the early to middle 1990's. The modeling categories and their corresponding USGS classifications are presented in Table 5-1. The land use acreages for the Seventeen Mile River watershed used in modeling are presented in Table 4-1 and the graphical display in Figure 4-1.

**Table 5-1. Land Use Representation.**

Land Categories Represented in the Model	MRLC Land Use Code	MRLC Land Use Classes	% Impervious
Built-up	21	Low Intensity Residential	19
	22	High Intensity Residential	65
	23	High Intensity Comm./Ind./Trans.	80
	33	Transitional	10
Forest	31	Bare Rock/Sand/Clay	0
	32	Quarries/Strip Mines/Gravel Pits	0
	41	Deciduous Forest	0
	42	Evergreen Forest	0
	43	Mixed Forest	0
	51	Deciduous Shrubland	0
	52	Evergreen Shrubland	0
	53	Mixed Shrubland	0
	71	Grassland/Herbaceous	0
85	Other Grasses	0	
Wetland	91	Woody Wetlands	0
	92	Emergent Herbaceous Wetlands	0
Cropland	61	Planted/Cultivated	0
	82	Row Crops	0
	83	Small Grains	0
	84	Bare Soil	0
Pasture	81	Pasture/Hay	0

The HSPF model requires division of land uses in each subwatershed into separate pervious and impervious land units. For each land use, this division can be made based on typical imperviousness percentages from individual land use categories, such as those used in the Soil Conservation Service's TR-55 method. For modeling purposes, the percent imperviousness of a give land category can be calculated as an area-weighted average of land use classes encompassing the modeling land category.

#### *Hydrologic Representation*

Watershed hydrology plays an important role in the determination of nonpoint source flow and ultimately nonpoint source loadings to a waterbody. The watershed model must appropriately represent the spatial and temporal variability of hydrologic characteristics within a watershed. Key hydrologic characteristics include interception storage capacities, infiltration properties, evaporation and transpiration rates, and watershed slope and roughness. The HSPF modules used to represent watershed hydrology for TMDL development include PWATER (water budget simulation for pervious land units) and IWATER (water budget simulation for impervious land units). A detailed description of relevant hydrologic algorithms is presented in the HSPF User's Manual.

#### *Water Quality Representation*

A total of four water quality parameters were simulated using the watershed model: biochemical



oxygen demand (BOD,) total nitrogen (TN), total phosphorus (TP), and total suspended solids (TSS). These parameters (either directly or indirectly) constitute the primary nonpoint sources contributing to dissolved oxygen depletion and/or replenishment. The buildup and washoff of these pollutants were represented using the PQUAL (simulation of quality constituents for pervious land segments) and IQUAL (simulation of quality constituents for impervious land segments) modules in HSPF. Different buildup and washoff rates were used to represent the different land categories (e.g. fertilizer and manure application generally result in a higher nutrient buildup and washoff from cropland than from urban lands). Upon application to the receiving water model, many of parameters simulated in the watershed model were converted into more applicable constituents for in-stream modeling.

#### *Leaf Litterfall Representation*

Loadings of leaf litterfall were assumed to be consistent with a study performed on the Ogeechee River in southern Georgia (Meyer et al. 1997). The direct leaf litterfall was reported as 843 g/m<sup>2</sup>/yr and lateral leaf litterfall was reported as 3,520 g/m<sup>2</sup>/yr. The surface area of the stream channel was used to derive loading rates into the model. The lateral leaf litterfall was flow dependent to simulate the loading increase when the flows are large enough to inundate the floodplains. During the higher flows, the organic material deposited in the floodplain is picked up and transported into the stream.

The leaf litterfall loading was only applied to the receiving water model grid segments (during simulation of each impaired river segment). Loadings from the HSPF model (particularly BOD, which was ultimately converted to TOC) were assumed to account for residual leaf litterfall from upstream segments (transported to the impaired segment). The majority of leaf litter was assumed to be deposited on the stream bottom within each segment, thus forming an organic-enriched bed, resulting in higher simulated Sediment Oxygen Demand (SOD).

#### *Point Source Representation*

After identifying all point source facility locations in the subwatersheds contributing to the impaired waterbodies, appropriate facilities were represented in the linked models. Depending on location, point sources were either represented in the watershed model or the receiving water model. Facilities discharging within a Georgia 12-digit subwatershed containing an impaired waterbody were represented as direct inputs into the receiving water model. Facilities discharging within a subwatershed representing an unimpaired waterbody were represented in the watershed model.

In the later case, the facilities discharge into waterbodies that eventually feed into an impaired waterbody, and thus must be considered in the source representation. Due to their indirect impact on the impaired waterbody, however, their contributions are subject to fate and transport in the watershed model through a stream system leading to the impaired waterbody.

Point source facilities were represented in both the watershed and receiving water models using a constant flow and pollutant loading. DMR data (flow and pollutant concentrations or loads) were represented in the models to simulate existing conditions – for calibration. Permitted flows and loads were used to represent initial conditions for TMDL development. The monthly average permitted conditions were loaded into the in-stream model for the allocation runs. For example, where BOD<sub>5</sub> is permitted at a maximum of 45 mg/L and an average of 30 mg/L, the average of 30

mg/L would be multiplied by the average daily, permitted flow to produce a daily mass loading (lbs/day). The monthly average permitted values, versus the monthly maximum, are more representative in determining assimilative capacity in the system. In special circumstances, such as a major point source discharge, a step-function would be implemented so that the waterbody would receive a maximum daily load during the month, but still maintain the permitted monthly average. Water quality constituents represented include BOD, TN, TSS, and TP. BOD and TSS values were represented using DMR and permitted values. TN values were based on monitored NH<sub>3</sub> values for the facilities. TP values were assumed to be 5 mg/L for municipal facilities (due to the absence of DMR data and permitted values). Refer to Table 4-1 for point source flows and loads used in the modeling process.

### In-stream Representation

The receiving water model, EFDC, was used to simulate all in-stream dissolved oxygen processes for the impaired waterbodies. Impaired waterbodies received flow and water quality output from the corresponding HSPF model (which represented watershed contributions). Unimpaired waterbodies located in stream networks contributing to impaired waterbodies were not represented explicitly using EFDC, but instead were represented using HSPF in-stream algorithms. Key components of the in-stream representation include:

- Hydrodynamic representation
- Water quality configuration
- Unimpaired waterbody representation

### Hydrodynamic Representation

Independent grid systems were developed to represent impaired waterbodies using EFDC, except in the case where multiple impaired waterbodies were connected. In these situations extended grids representing the entire impaired system were developed. The longitudinal extent of each waterbody impairment, as defined in the Georgia 303(d) list, was used to determine the grid coverage. In general, the grid for each impairment was extended to the waterbody's intersection with the nearest up- and down-stream Georgia 12-digit subwatershed boundary. This standardized the grid development processes, as well as the watershed model-receiving water model linkage. Under this configuration, the entire extent of each impairment was fully represented.

The extent of impairment in Seventeen Mile River was 8 miles. Each cell was rectangular and represented a single vertical water layer (one dimension). Cells were typically on the order of 1 km (0.62 mi) to 3.22 km (2 mi) in length. Lateral dimensions were derived from USGS cross-sectional data obtained from USGS monitoring stations located on each of the impaired segments.

Tributary inflows, point sources, and nonpoint source contributions were applied directly to applicable cells in the grid. For impaired headwaters, the total flow from the contributing 12-digit subwatershed was divided into two portions. The first portion (typically 20% of the flow) was applied directly into the most upstream cell, while the remaining portion (typically 80%) was divided equally among the remaining cells to represent nonpoint source inflows.

For downstream impairments, upstream inflows (represented in the watershed model) were applied

directly to the most upstream cell in the grid. Flow from the 12-digit subwatershed(s) in immediate vicinity of the impaired waterbody (also represented in the watershed model) were distributed evenly among the cells. Flow from incoming tributaries (represented as stream networks in the watershed model) and point sources were applied directly to the most appropriate cell in the configuration. Figure 5-1 presents an example of the in-stream configuration for an impaired headwater and its linkage to the watershed model.

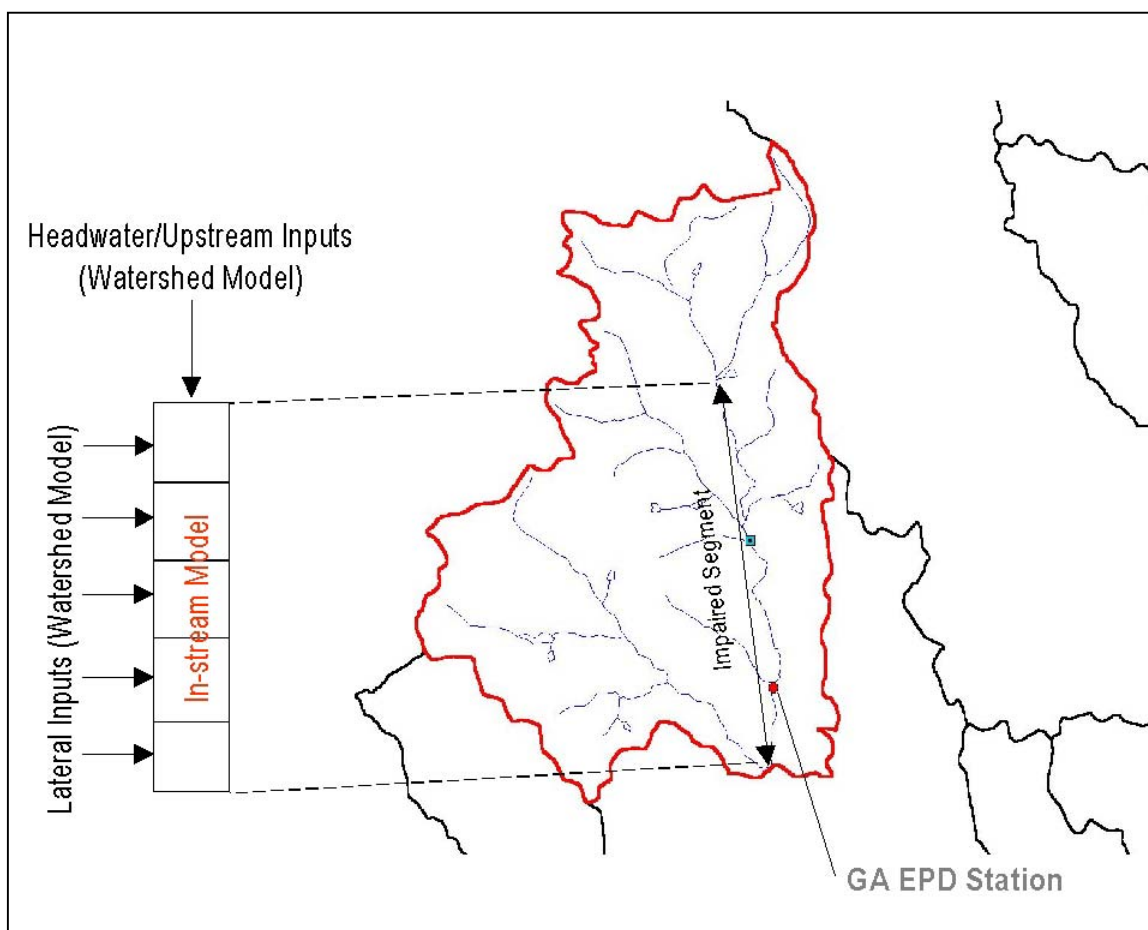

**Figure 5-1. Diagram of In-stream Model Configuration.**

The hydrodynamic portion of the EFDC model is designed to solve three-dimensional, vertically hydrostatic, free surface, turbulent averaged equations of motion for a variable-density fluid. The model uses stretched or sigma vertical coordinates and Cartesian or curvilinear, orthogonal horizontal coordinates. Dynamically-coupled transport equations for turbulent kinetic energy, turbulent length scale, salinity and temperature are also solved. The two turbulence parameter transport equations implement the Mellor-Yamada level 2.5 turbulence closure scheme (Mellor & Yamada, 1982) as modified by Galperin et al (1988). The EFDC model also simultaneously solves an arbitrary number of Eulerian transport-transformation equations for dissolved and suspended materials. The EFDC model allows for drying and wetting in shallow areas by a mass conservation scheme. A number of alternatives are in place in the model to simulate general discharge control structures such as weirs, spillways and culverts. The theoretical and computational basis for the model is documented in Hamrick (1992a).

## Water Quality Configuration

Simulation of dissolved oxygen in the receiving water model considered a large suite of model state variables and kinetic processes. The EFDC model simulates the interactions between up to 21 state variables including dissolved oxygen, suspended algae (3 groups), various components of carbon, nitrogen, phosphorus and silica cycles, and fecal coliform bacteria. The kinetic processes included in this model use the Chesapeake Bay three-dimensional water quality model, CE-QUAL-ICM (Cerco & Cole, 1994). Figure 5-2 is a schematic diagram of the EFDC water column water quality model.

The primary sources and sinks of oxygen represented in the EFDC model are:

- algal photosynthesis and respiration
- nitrification
- heterotrophic respiration of dissolved organic carbon
- oxidation of chemical oxygen demand (COD)
- surface reaeration
- sediment oxygen demand (SOD)
- external loads

Refer to *A Three-Dimensional Hydrodynamic-Eutrophication Model (HEM-3D): Description of Water Quality and Sediment Process Submodels (EFDC Water Quality Model)* for a full description of relevant equations and formulations.

In order to represent all sources and sinks of dissolved oxygen, the water quality model required temperature representation and inputs of water quality parameters from the watershed model and point source discharges. For calibration purposes, in-situ temperature data measured concurrently with dissolved oxygen was input into the model. For the allocation model runs, a representative, seasonal distribution of temperature was created for the entire southern four basins. The data used to create the seasonal pattern in the model was collected by the USGS at the 5 monitoring sites in Georgia. The monitoring site that was the closest to the southern four basins in Georgia was at USGS02213700 on the Ocmulgee River near Warner Robbins, Georgia. A sinusoidal function was used to fit to the daily maximum and minimum from the Ocmulgee River station to create the representative temperature for the allocation runs.

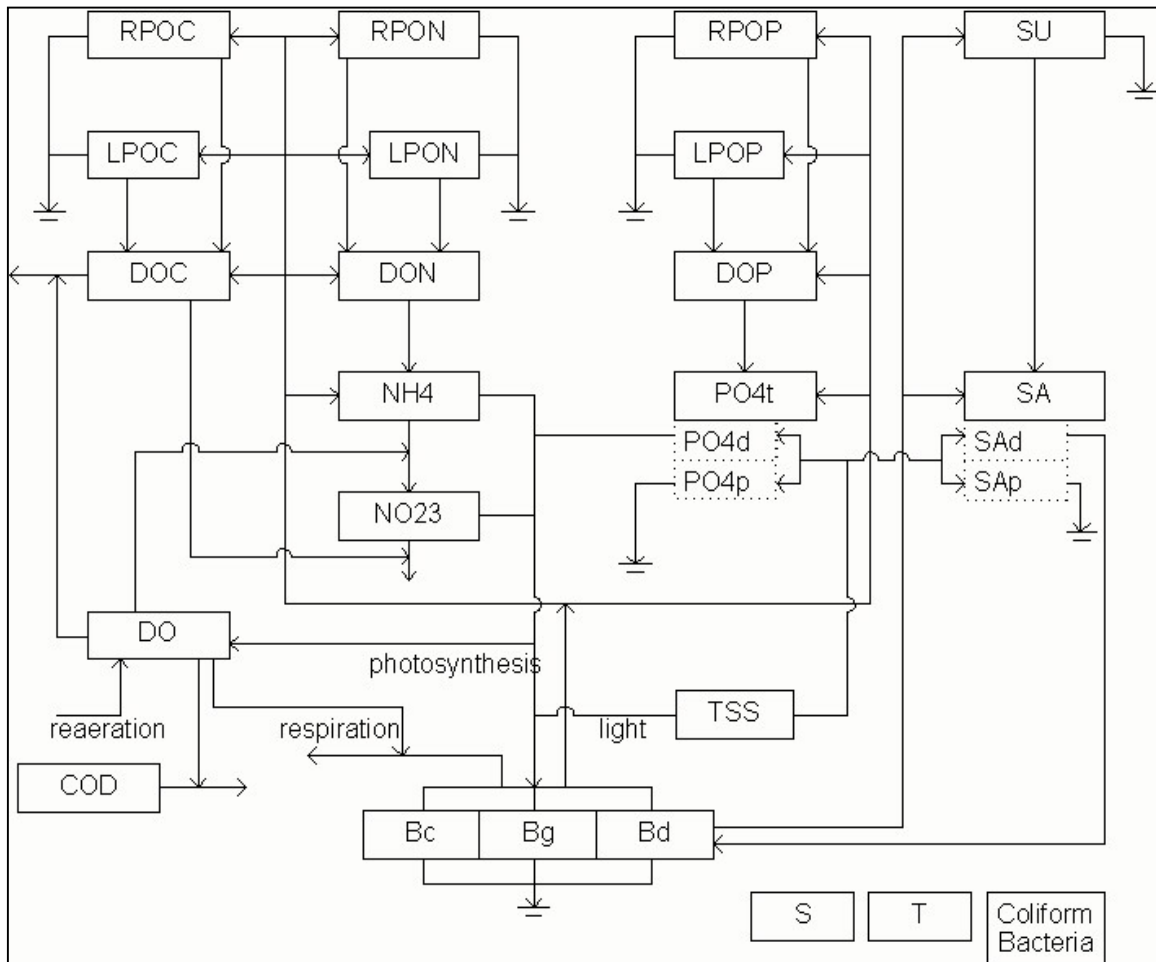

**Figure 5-2. EFDC water column water quality model schematics diagram.**

Water quality parameters were input to cells in the grid using the same procedure as for flow. All upstream inputs, tributary inputs, point sources, and nonpoint source contributions in immediate vicinity of the impaired waterbody were accounted for. Specific parameters transferred from the watershed model (and point sources) to the receiving water model included TSS, BOD, TN, and TP.

#### *BOD5 to Total Organic Carbon*

The HSPF subwatershed model runs were calibrated primarily to 5-day biochemical oxygen demand (BOD5) and total suspended solids (TSS). Due to the inherent solutions of the water quality models, it was necessary to convert the BOD5 from the point and nonpoint sources to TOC. The watershed loads simulated by HSPF are with respect to BOD5, TN, TP, and TSS. EFDC is a carbon-based water quality model, and therefore, the model simulates organic matter as carbon rather than BOD. Therefore, to put the watershed loads into the in-stream model, BOD5 had to be converted to TOC. By breaking the ratio down into a BODU/BOD5 and TOC/BODU components, the multiplier was justified by a typical in-stream f-ratio (ratio of ultimate BOD to a 5-day BOD) of 4.0 and literature

value for converting ultimate BOD to TOC of 2.7 (Thomann and Mueller, 1987). Therefore, an 11.0 (sensitivity ranged from 10.8 to 11.2) multiplier was initially used to convert BOD5 to TOC.

### Unimpaired Waterbody Representation

Unimpaired waterbodies contributing to impaired segments were represented as a component of the watershed model. The RCHRES and GQUAL HSPF modules were used to simulate in-stream flow and general water quality. Flow determination using HSPF required development of rating curves for each stream modeled. Rating curves were developed for streams using cross-sectional dimensions estimated from regional watershed area-bankfull channel dimension curves (Rosgen, 1996). No explicit water quality interactions were represented using the GQUAL module. General first-order decay was used to represent all processes typically influencing the fate of water quality parameters, e.g. transformation, settling, etc.

### Model Testing

After developing the watershed and receiving water models to represent source contributions and in-stream response, the models were tested for validity. This testing is typically referred to as model calibration, and it involves the comparison of simulated results to observed data and the subsequent adjustment of model parameter values. Calibration of the linked models was performed for the year 1998, due to the availability of monitoring data. Hydrology and water quality were first calibrated for the watershed model. Once the preliminary calibration results from the watershed model were applied to the receiving water model, calibration of the receiving water model ensued. Calibration of the receiving water model additionally required further calibration of the watershed model, and thus an iterative approach to calibration was taken.

### Watershed Model Hydrology Calibration

Hydrologic calibration involved an adjustment of parameters related to all components of the hydrologic cycle including overland flow, infiltration, groundwater flow, and evapotranspiration. Adjustments were made during a comparison of in-stream flow monitoring data to modeled in-stream flow at a representative location for the region. The location selected was Little Satilla River near Offerman, GA (USGS02227500). The entire drainage area contributing to flow at this station was modeled and results were compared to the monitoring data. After making appropriate adjustments, the model results showed a good correlation with the observed values. The resulting hydrology parameters were validated at two additional stations in the region; Withlacoochee River at McMillan Road near Bemiss, Georgia and Okapilco Creek at Route 33 near Quitman, Georgia. Once hydrologic parameters were calibrated and validated, the values were applied to the remaining subwatersheds in the basin.

### Watershed Model Water Quality Calibration

Once hydrology was calibrated and validated for the watershed model, calibration of water quality parameters was necessary. Water quality calibration consisted of adjusting TSS, BOD, TN, and TP buildup and washoff parameters within a reasonable range to achieve a good match between model

output and in-stream water quality observations. Key considerations in the water quality calibration for the watershed model were baseflow concentrations, background concentrations, seasonal variations, and stormflow concentrations.

Initial buildup and washoff parameters were based on past studies in the southeast, including the *Nonpoint Source Pollutant Loading Evaluation - ACT and ACF Water Allocation Formula - Environmental Impact Statements* and *Water-Quality Improvements in the Lower Mississippi River Valley – Analysis of Nutrient Loadings in the Yazoo River Basin*. Each land use category was represented by a different buildup and washoff rate, in order to simulate the variability between load contributions from different sources. The parameters were adjusted through a comparison of model output to typical loading rates from various land uses and monitoring data. As with the hydrology parameters, water quality parameter values were additionally applied to the remaining subwatersheds in the basin.

### Receiving Water Model Calibration

Kinetic parameters that required adjustment included reaeration formula, ratios for nutrient splits, leaf litterfall nutrient split, and density of periphyton. For the in-stream, EFDC model runs, the primary water quality parameters for evaluating a calibrated model were dissolved oxygen and TOC. Secondary parameters include ammonia, nitrate-nitrite, total nitrogen, and total phosphorus. Sediment Oxygen Demand (SOD) and Chemical Oxygen Demand (COD) benthic flux were also examined to see how much oxygen demand was derived by the sediment. In addition to the water quality calibration, flow, velocity, and depth were examined to ensure proper calibration of the hydrodynamics.

The dissolved oxygen calibration for Seventeen Mile River is shown in Figure 5-3. The instream model was calibrated for the following parameters in EFDC: flow, velocity, depth, temperature, dissolved oxygen, ammonia nitrogen, nitrite-nitrate nitrogen, total phosphorus, total organic carbon, and total suspended sediment.

The oxygen balance was calibrated by making adjustments to reaeration, algal growth and death, instream kinetic rates, partitioning coefficients for sediment fluxes, and water temperatures.

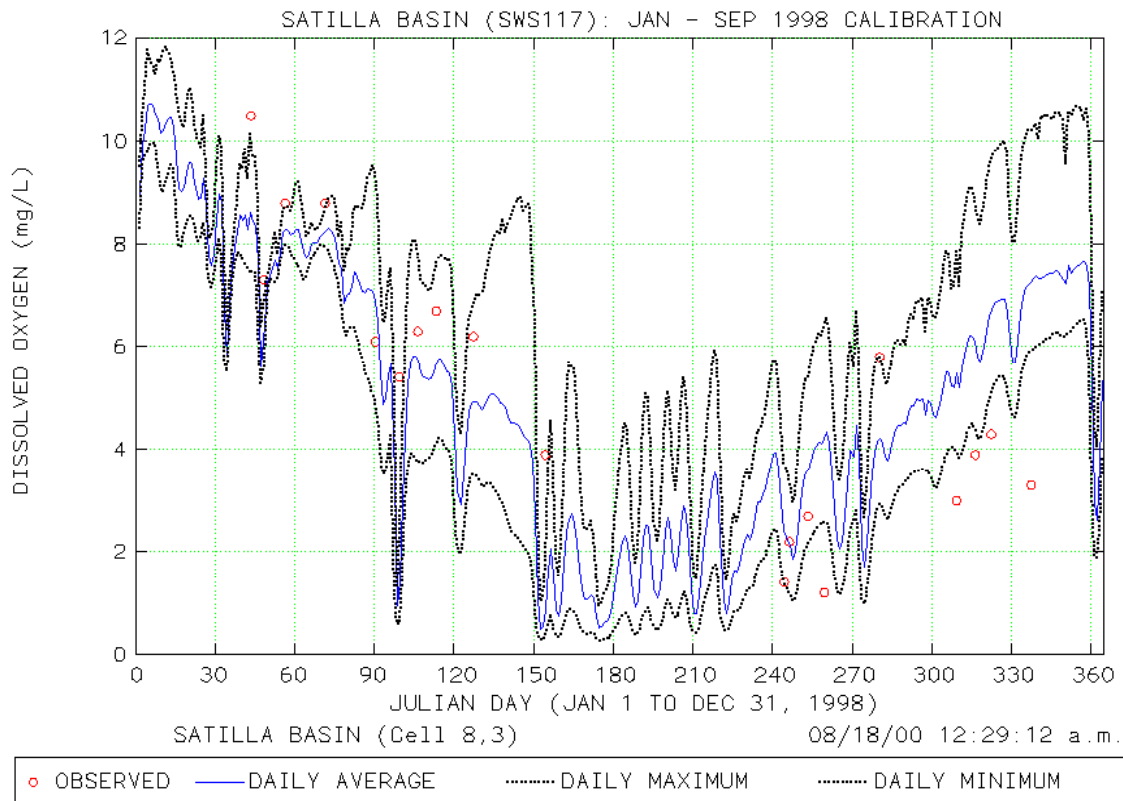

**Figure 5-3. Seventeen Mile River Dissolved Oxygen Calibration.**

## 6.0 Loading Capacity

The tested model was ultimately used to identify the allowable loading capacity for the listed segment. The first step in the process was to determine naturally occurring dissolved oxygen concentrations for the impaired waterbody. By doing so, the applicable water quality standard used for TMDL development was identified.

To determine the naturally occurring dissolved oxygen concentrations, the in-stream model was run using watershed model input representing pristine conditions (entirely forest and wetland contributions) and leaf litterfall. The resultant in-stream dissolved oxygen concentrations represented natural conditions. The range of values was representative of naturally low dissolved oxygen concentrations and was below 110% of the state water quality standard, therefore the EPA criteria was instituted and dissolved oxygen target limits were identified for TMDL development. The target limits were identified as 90% of the minimum naturally occurring concentration for impaired waterbody.

After identifying the dissolved oxygen target limits, the models were run to determine the loading capacity of the waterbody. This was done through a series of simulations aimed at meeting the dissolved oxygen target limit by varying source contributions. The final acceptable scenario



represented the TMDL (and loading capacity of the waterbody). Subsequent sections of this report present components of the TMDL.

### Confirmation of Waterbodies Reaching Dry Conditions

An analysis of USGS daily discharge data at selected gaging stations located throughout the southern four Georgia basins suggests that many streams in the region actually exhibit no-flow conditions for extended periods of time. Several of the impaired waterbodies dry for significant periods of time throughout the year. Analysis of water quality is virtually impossible during no-flow conditions and situations where streams contain no flow or pooled non flowing water. Seven stations were selected for the analysis. Each station is located on a unique waterbody representing a drainage area between 139 and 1,260 mi<sup>2</sup> (Table 6-1).

**Table 6-1. USGS Gaging Stations and Characteristics.**

USGS Gaging Station ID	Drainage Area (mi <sup>2</sup> )	Waterbody	Basin	Period of Record
02227000	139	Hurricane Creek	Satilla	10/1/51 - 10/8/71
02227500	646	Little Satilla River	Satilla	1/27/51 - 9/30/98
02314500	1,260	Suwannee River	Suwannee	4/20/37 - 9/30/98
02316000	663	Alapaha River	Suwannee	4/26/37 - 9/30/76
02317755	537	Withlacoochee River	Suwannee	10/20/76 - 1/4/90
02318000	577	Little River	Suwannee	6/12/40 - 9/30/71
02318700	269	Okapilco Creek	Suwannee	12/21/79 - 9/30/98

The three stations representing the smallest drainage areas (02227000, 02317755, and 02318700) had no-flow days more than 9% of the time. The remaining stations, representing larger watersheds, exhibited no-flow conditions less than 1% of the time. Although the timing of no-flow conditions varied from one waterbody to the next, the most common months exhibiting no-flow conditions were October, November, and June. Precipitation data for the basin supports these trends in that October and November are typically the driest months, and June often exhibits lower rainfall totals (compared to other months). Refer to Appendix A for detailed information regarding precipitation at appropriate weather stations in the basin. Table 6-2 presents information, by station, related to no-flow time periods.

**Table 6-2. No-Flow Characteristics for Selected USGS Gaging Stations.**

USGS Gaging Station ID	Days with No Flow	Total Days	% of Days with No Flow	Month with Most No-Flow Days
02227000	745	7306	10.20	June
02227500	50	17414	0.29	October
02314500	74	22,444	0.33	November
02316000	106	14403	0.74	October
02317755	142	1233	11.52	November
02318000	17	11433	0.15	June
02318700	683	6859	9.96	October

Under no-flow conditions, the development or determination of an appropriate naturally occurring

dissolved oxygen water quality standard is not possible or appropriate. Therefore, when using the models to identify minimum dissolved oxygen concentrations under natural conditions, no-flow periods were not considered. The minimum dissolved oxygen concentrations and related loadings were identified only during periods when there was flow in the stream.

## 7.0 Waste Load and Load Allocations

Two critical components of the TMDL are the Waste Load Allocations (WLAs) and the Load Allocations (LAs). The WLAs represent the load allocations to point source facilities contributing to impaired waterbodies, while the LAs represent load allocations to the nonpoint source contributions. LAs are assumed to represent all watershed and leaf litterfall loads to the impaired waterbody. The LAs are divided into subwatersheds (representing all subwatersheds contributing to an impaired waterbody).

The WLAs and LAs presented in Tables 7-1 and 7-2 represent successful allocation scenarios (in which the dissolved oxygen target limit is met). WLAs and LAs sum to represent the entire TMDL, because MOS is implicitly considered through model assumptions.

The partitioning of allocations between point (WLA) and nonpoint (LA) sources was based on modeling results and professional judgment to meet the TMDL. The WLAs may be modified by GAEPD during the NPDES permitting process. The TMDLs will be used to assess the permit renewals in the impaired segments.

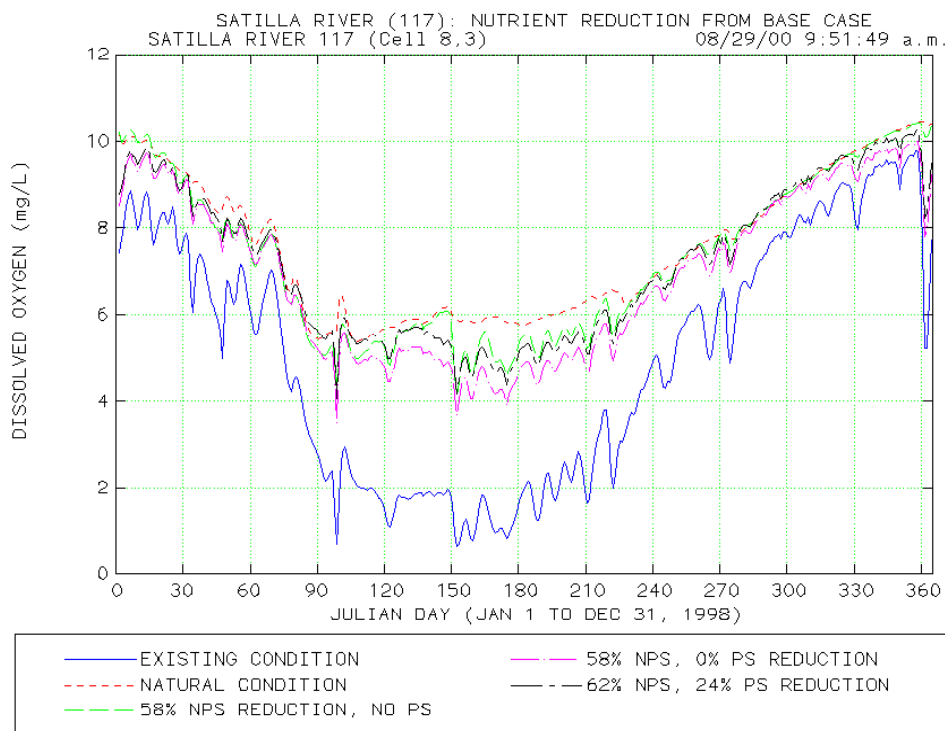

**Figure 7-1. Seventeen Mile River Dissolved Oxygen Allocations.**

**Table 7-1. TMDL Results for Upstream Seventeen Mile River Segment.**

Seventeen Mile River - Upstream Segment				TMDL = WLA + LA					
				TOC(lb/yr)	TN(lb/yr)	TP(lb/yr)			
				12,235,204	452,404	117,591			
Nonpoint Sources (LA)	TOC(lb/yr)	TN(lb/yr)	TP(lb/yr)	TOC(lb/yr)	TN(lb/yr)	TP(lb/yr)	TOC(lb/yr)	TN(lb/yr)	TP(lb/yr)
Contributing Subwatersheds	Existing Loads			Allocation Loads (LA)			% Reduction		
030702010401(a)	1,410,402	80,931	9,164	651,889	37,407	4,236	54	54	54
030702010401(b)	2,575,904	98,794	11,963	1,636,840	62,778	7,602	36	36	36
030702010401(c)	2,198,698	97,785	9,405	1,443,595	64,202	6,175	34	34	34
030702010402	3,916,922	119,340	15,840	2,394,423	72,953	9,683	39	39	39
030702010403(a)	743,306	22,808	2,387	515,864	15,829	1,657	31	31	31
030702010403(b)	3,296,049	117,178	14,233	2,162,330	76,873	9,338	34	34	34
030702010404	1,665,497	89,421	9,767	806,410	43,296	4,729	52	52	52
030702010501	2,104,950	73,903	7,770	1,291,267	45,336	4,767	39	39	39
Total	17,911,728	700,160	80,529	10,902,619	418,673	48,185			
Point Sources (WLA)	Existing Loads			Allocation Loads (WLA)			% Reduction		
Douglas Southeast WPCP (GA0024431)	1,753,402	44,383	91,323	1,332,585	33,731	69,405	24	24	24
Total	1,753,402	44,383	91,323	1,332,585	33,731	69,405			

**Table 7-2. TMDL Results for Downstream Seventeen Mile River Segment.**

Seventeen Mile River - Downstream Segment#2				TMDL = WLA + LA					
				TOC(lb/yr)	TN(lb/yr)	TP(lb/yr)			
				21,939,495	751,265	154,464			
Nonpoint Sources (LA)	TOC(lb/yr)	TN(lb/yr)	TP(lb/yr)	TOC(lb/yr)	TN(lb/yr)	TP(lb/yr)	TOC(lb/yr)	TN(lb/yr)	TP(lb/yr)
Contributing Subwatersheds	Existing Loads			Allocation Loads (LA)			% Reduction		
030702010401(a)	1,410,402	80,931	9,164	651,889	37,407	4,236	54	54	54
030702010401(b)	2,575,904	98,794	11,963	1,636,840	62,778	7,602	36	36	36
030702010401(c)	2,198,698	97,785	9,405	1,443,595	64,202	6,175	34	34	34
030702010402	3,916,922	119,340	15,840	2,394,423	72,953	9,683	39	39	39
030702010403(a)	743,306	22,808	2,387	515,864	15,829	1,657	31	31	31
030702010403(b)	3,296,049	117,178	14,233	2,162,330	76,873	9,338	34	34	34
030702010404	1,665,497	89,421	9,767	806,410	43,296	4,729	52	52	52
030702010501(a)	2,104,950	73,903	7,770	1,291,267	45,336	4,767	39	39	39
030702010501(b)	1,026,027	45,484	4,813	803,899	35,637	3,771	22	22	22
030702010502	3,531,642	97,779	12,981	2,871,410	79,499	10,555	19	19	19
030702010503	3,372,419	90,201	12,399	2,711,630	72,527	9,969	20	20	20
030702010504	3,726,878	124,925	14,131	3,317,352	111,197	12,578	11	11	11
Total	29,568,695	1,058,548	124,853	20,606,910	717,534	85,058			
Point Sources (WLA)	Existing Loads			Allocation Loads (WLA)			% Reduction		
Douglas Southeast WPCP (GA0024431)	1,753,402	44,383	91,323	1,332,585	33,731	69,405	24	24	24
Total	1,753,402	44,383	91,323	1,332,585	33,731	69,405			

The TMDL analysis determined that a 24% point source reduction to GA0024431 and an 11 to 54% nonpoint source reduction would meet the instream dissolved criteria of 5.0 mg/L for a daily average. For the point source compliance, the TOC load will be converted to a BOD5 load to be consistent with NPDES permits. Each contributing watershed is given its own reduction in the nonpoint source load.

### 8.0 Margin of Safety

The margin of safety (MOS) is part of the TMDL development process. There are two basic methods for incorporating the MOS (USEPA, 1991):

- Implicitly incorporate the MOS using conservative model assumptions to develop allocations, and
- Explicitly specify a portion of the total TMDL as the MOS; use the remainder for allocations.

The MOS was considered implicitly in the TMDL development process. Conservative modeling assumptions include:

- Running dynamic model,
- Permitted point sources are loaded into model for allocation runs (average monthly permit values), taking into account the daily maximum loads,
- Running model with actual flow and temperature during one or more annual cycles including

- a critical summer period, and
- 41% saturation for upstream dissolved oxygen (Meyer, 1992).

## **9.0 Seasonal Variation**

The Statute and regulations require that a TMDL be established with consideration of seasonal variations. Seasonal variation was considered through dynamic representation of a full calendar year. The model simulations included a wide range of hydrologic and pollutant loading scenarios and led to development of a TMDL corresponding to these scenarios.

## **10.0 Monitoring Plan**

The GAEPD has adopted a basin approach to water quality management; an approach that divides Georgia's major river basins into five groups. Each year the GAEPD water quality monitoring resources are concentrated in one of the basin groups. One goal is to continue to monitor 303(d) listed waters. This monitoring will occur in the next monitoring cycle for the Suwannee in 2003 and will help further characterize water quality conditions resulting from the implementation of best management practices in the watershed.

## **11.0 Point and Nonpoint Source Approaches**

Permitted discharges will be regulated through the NPDES permitting process described in this report. The total organic carbon nonpoint source loading to the streams in the Seventeen Mile River watershed is made up of a combination of naturally occurring leaf litter and anthropogenic non-point source loads. Because most of the oxygen demanding loadings to the streams in the Seventeen Mile River watershed is the result of nonpoint sources, the implementation goal for nonpoint sources will be to reduce the loading from anthropogenic non-point source loads. The reduction in anthropogenic non-point source loading should lead to the attainment of water quality standards. To ensure that anthropogenic non-point source load reductions occur in the Seventeen Mile River watershed, Georgia EPD will work with the Natural Resource Conservation Service (NRCS), the Georgia Soil and Water Conservation Commission (GSWCC), and the Georgia Forestry Commission to implement best management practices (BMPs) to reduce anthropogenic nonpoint source loading of total organic carbon. Implementation of BMPs to reduce anthropogenic non-point source loading of total organic carbon is expected to lead to the attainment of water quality standards.

## **12.0 Public Participation**

A thirty-day public notice will be provided for this TMDL. During that time, the availability of the TMDL will be public noticed, a copy of the TMDL will be provided upon request, and the public will be invited to provide comments on the TMDL.

### 13.0 References

- Bicknell, B.R. et al., 1996. Hydrological Simulation Program – Fortran (HSPF) User's Manual for Release 11. Environmental Research Laboratory, Office of Research and Development, USEPA, Athens, GA.
- Cerco, C.F. and T.M. Cole, 1994. Three-dimensional eutrophication model of Chesapeake Bay: Volume 1, main report. Technical Report EL-94-4, US Army Engineer Waterways Experiment Station, Vicksburg, MS.
- DiToro, D.M. and J.J. Fitzpatrick, 1993. Chesapeake Bay sediment flux model. Contract Report EL-93-2, US Army Engineer Waterways Experiment Station, Vicksburg, MS.
- Dyar, T.R. and S.J. Alhadeff, 1997. Stream-Temperature Characteristics in Georgia. United States Geological Survey prepared in cooperation with the Georgia Department on Natural Resources Environmental Protection Division, Water-Resources Investigations Report 96-4203.
- Edwards, R.T. and J.L. Meyer, 1987. Metabolism of a subtropical low gradient blackwater river.” *Freshwater Biology*, 17:251-263.
- Galperin, B., L.H. Kantha, S. Hassid, and A. Rosati, 1988. A quasi-equilibrium turbulent energy model for geophysical flows. *Journal of Atmospheric Sciences*, 45, 55-62.
- Georgia EPD, 1996. Georgia's Watershed Protection Approach: River Basin Management Planning, Draft Program Description. February 1996.
- Georgia EPD, 2000. *Rules and Regulations for Water Quality Control. Chapter 391-3-6*. Revised – July 2000. Georgia Department of Natural Resources. Environmental Protection Division. Atlanta, GA.
- Hamrick, J.M., 1992. A three-dimensional environmental fluid dynamics computer code: theoretical and computational aspects. The College of William and Mary, Virginia Institute of Marine Science. Special Report 317, 63pp.
- Hamrick, J.M., 1996. User's Manual for the Environmental Fluid Dynamics Computer Code. Special Report No. 331 in Applied Marine Science and Ocean Engineering, Department of Physical Sciences, School of Marine Sciences, Virginia Institute of Marine Sciences.
- Mellor, G.L. and T. Yamada, 1982. Development of a turbulence closure model for geophysical fluid problems. *Rev. Geophys. Space. Phys.*, 20, 851-875.
- Meyer, J.L., 1992. Seasonal patterns of water quality in blackwater rivers of the Coastal Plain, Southeastern United States. *Water Quality in North American River Systems*, Battelle Press, Columbus, Ohio, pages 249-276.
- Meyer et al., 1997. Organic matter dynamics in the Ogeechee River, a blackwater river in Georgia, USA. *Journal of the North American Benthological Society*, 16(1):1.

- Novotny et al., 1989. *Karl Imhoff's handbook of urban drainage and wastewater disposal*. Wiley, New York.
- Park, K. et al., 1995. A Three-Dimensional Hydrodynamic-Eutrophication Model (HEM-3D) Description of Water Quality and Sediment Process Submodels (EFDC Water Quality Model). Special Report No. 327 in Applied Marine Science and Ocean Engineering, Department of Physical Sciences, School of Marine Sciences, Virginia Institute of Marine Sciences.
- Sierra Club v. Hankinson. Civil Action File No. 1: 94-CV-2501-MHS. Consent decree signed 7/15/97.
- Thomann, R.V. and J.A. Mueller, 1987. Principles of surface water quality modeling and control. Harper Collins Publishers Inc., New York.
- U.S. Army Corps of Engineers. 1998. Nonpoint Source Pollutant Loading Evaluation-ACT and ACF Water Allocation Formula-Environmental Impact Statements.
- USEPA, 1991. *Guidance for Water Quality Based Decisions: The TMDL Process*. EPA 440/4-91-001. U.S. Environmental Protection Agency; Assessment and Watershed Protection Division, Washington, DC.
- USEPA Region 4, 1999. Draft – Water Quality Improvements in the Lower Mississippi River Valley: Analysis of Nutrient Loading in the Yazoo River Basin.
- USEPA, 1986. Ambient Aquatic Life Water Quality Criteria for Dissolved Oxygen (Freshwater). Office of Water Regulations and Standards Criteria and Standards Division, EPA440/5-86-003.
- USGS, 1999. *National Water Data Storage and Retrieval System (WATSTORE)*. U.S. Geological Survey, Reston, VA.
- Wharton, C. H. and M. M. Brinson, 1979. Characteristics of southeastern river systems. Pages 32-40 in R. R. Johnson and J. F. McCormick, editors. Strategies for protection and management of floodplain wetlands and other riparian ecosystems. U. S. Forest Service General Technical Report WO-12. National Technical Information Service, Springfield, VA.

**Appendix A**  
**Data Used in TMDL Analysis**

**Table A-1. Water Quality Data Collected by USGS During 1998 at USGS 02226341 –  
Seventeen Mile River at SR 32 near Douglas, GA (EPD ID 07006001).**

Sample Date	Sample Time	Water Temp (deg C)	Air Temp (deg C)	Stage (feet)	Turbidity (NTU)	Specific Cond (uS/cm)	DO (mg/L)	BOD5 (mg/L)	pH	NH3 (mg/L)	NO2+NO3 (mg/L)	TP (mg/L)	TOC (mg/L)	Fecal Coliform (mpn)
02/12/1998	1050	12.0	17.0	6.01	6	45	10.5	1.0	6.3	0.03	0.15	0.04	12	130
02/17/1998	930	14.6	22.0	6.72		37	7.3		6.3					3500
02/25/1998	920	12.0	14.5	8.07		42	8.8		6.5					80
03/12/1998	1120	9.2	11.0	8.62	17	30	8.8	2.0	6.5	0.03	0.16	0.05	12	40
03/31/1998	945	20.5	23.0	5.29	6	50	6.1	1.2	6.5	0.04	0.11	0.09	16	
04/09/1998	940	18.6	25.0	5.68	8	46	5.4	2.5	6.3	0.09	0.16	0.08	19	2300
04/16/1998	850	17.3	24.0	5.61		47	6.3		6.4					80
04/23/1998	930	15.7	18.0	5.33		50	6.7		6.5					20
05/07/1998	845	19.7	23.0	5.36	5	51	6.2	1.4	6.5	0.03	0.10	0.10	17	230
06/03/1998	915	25.6	31.0	4.54	6	73	3.9	1.8	6.5	0.16	0.16	0.12	19	
07/09/1998	900			3.79										
07/16/1998	825													
07/23/1998	950													
09/01/1998	920	25.5	30.5	4.25	10	104	1.4	3.7	6.5	0.16	0.04	0.16	45	230
09/03/1998	1055	24.0	25.0	4.77	8	90	2.2	3.7	6.4	0.10	0.05	0.14	37	6000
09/10/1998	930	21.3	26.0	4.87	4	72	2.7	1.5	6.1	0.03	0.03	0.09	30	110
09/16/1998	1140	23.7	30.0	4.53		87	1.2		6.1					20
10/07/1998	910	24.0	27.5	5.40	5	80	5.8	1.8	6.2	0.03	0.05	0.08	31	
11/05/1998	1020	15.5	13.5	4.34	5	96	3.0	3.0	6.3	0.03	0.02	0.08	27	460
11/12/1998	1000	15.0	17.0	4.30		99	3.9		6.4					270
11/18/1998	955	17.0	18.0	4.40		98	4.3		6.3					460
12/03/1998	930	14.5	18.0	4.51	7	89	3.3	2.2	6.3	0.03	0.03	0.09	24	80
	min	9.2	11.0	3.79	4	30	1.2	1.0	6.1	0.03	0.02	0.04	12	20
	mean	18.2	21.8	5.32	7	68	5.1	2.2	6.4	0.06	0.09	0.09	24	876
	max	25.6	31.0	8.62	17	104	10.5	3.7	6.5	0.16	0.16	0.16	45	6000

**Table A-2. Water Quality Data Collected by USGS During 1998 at USGS 02226356 –  
Seventeen Mile River at SR 64 near Stokesville, GA (EPD ID 07016601).**

Sample Date	Sample Time	Water Temp (deg C)	Air Temp (deg C)	Stage (feet)	Turbidity (NTU)	Specific Cond (uS/cm)	DO (mg/L)	BOD5 (mg/L)	pH	NH3 (mg/L)	NO2+NO3 (mg/L)	TP (mg/L)	TOC (mg/L)	Fecal Coliform (mpn)
02/12/1998	1150	11.5	18.5	11.07	6	53	8.1	1.0	6.4	0.03	0.20	0.08	14	50
02/17/1998	1040	14.7	22.0	6.72		55	7.2		6.4					490
02/25/1998	1005	12.5	18.0	12.54		47	8.8		6.4					80
03/12/1998	1210	11.1	7.0	14.82	21	29	8.0	1.9	6.1	0.28	0.16	0.07	14	210
03/31/1998	1020	21.0	24.0	10.16	6	64	6.6	1.5	6.5	0.03	0.15	0.24	18	
04/09/1998	1030	19.0	25.0	10.26	8	72	5.0	1.6	6.4	0.08	0.20	0.23	20	410
04/16/1998	920	17.8	25.0	10.51		57	5.9		6.4					20
04/23/1998	1010	16.3	21.0	10.20		65	6.0		6.5					20
05/07/1998	920	20.7	25.0	11.40	7	67	5.2	1.0	6.4	0.03	0.09	0.24	19	40
06/03/1998	1000	25.8	32.0	8.77	6	172	3.3	1.0	6.7	0.04	0.15	0.31	20	
07/09/1998	945			5.86										
07/16/1998	900			5.78										
07/23/1998	1015													
08/06/1998	1050	23.9	31.0	8.52	6	390	3.8	1.4	6.2	0.09	0.03	0.26	22	170
08/11/1998	820	24.5	27.5	8.99	4	417	6.7	1.5	6.2	0.03	0.05	0.33	20	130
09/01/1998	950	25.5	32.5	8.71		205	2.4		6.7					170
09/03/1998	1125	24.0	25.0	9.19	5	194	3.2	2.0	6.7	0.03	0.06	0.66	34	790
10/07/1998	950	24.5	28.5	10.55	4	85	5.2	1.7	6.2	0.03	0.03	0.32	35	
11/05/1998	1105	16.0	14.5	8.82	3	247	4.9	2.0	6.5	0.03	0.02	0.24	22	160
11/12/1998	1035	16.5	17.0	8.91		276	4.7		6.6					170
11/18/1998	1030	17.5	20.5	8.94		321	4.2		6.6					330
12/03/1998	1010	15.5	17.0	8.80	3	398	5.1	1.5	6.7	0.03	0.02	0.17	15	330
	min	11.1	7.0	5.78	3	29	2.4	1.0	6.1	0.03	0.02	0.07	14	20
	mean	18.9	22.7	9.50	7	169	5.5	1.5	6.5	0.06	0.10	0.26	21	223
	max	25.8	32.5	14.82	21	417	8.8	2.0	6.7	0.28	0.20	0.66	35	790



**TOTAL MONTHLY PRECIPITATION (IN)**

Station: PEARSON (GA6879)

Analysis Period: 50 years (from June, 1948 to May, 1998)

Month	Count	Mean	Min	Max	St Dev	Median	25th	75th
January	50	3.78	0.14	12.84	2.42	3.65	1.90	5.28
February	50	4.12	0.60	12.80	2.26	4.05	2.25	5.48
March	50	4.40	0.14	11.20	2.52	3.80	2.52	5.62
April	50	3.21	0.20	8.50	2.31	2.80	1.40	4.78
May	50	3.22	0.21	9.37	2.06	2.76	1.80	4.48
June	50	4.61	1.02	9.80	2.12	4.41	2.87	5.52
July	50	6.04	2.46	13.10	2.08	5.95	4.74	7.28
August	50	5.52	1.18	12.40	3.00	4.43	3.34	6.85
September	50	3.49	0.20	8.51	2.10	3.27	2.03	4.98
October	50	2.60	0.00	8.70	2.19	1.86	1.06	3.51
November	50	2.25	0.10	6.10	1.60	1.87	0.93	3.33
December	50	3.41	0.00	10.00	2.09	2.85	2.03	4.57

Monthly Precipitation (Mean, Min, Max)

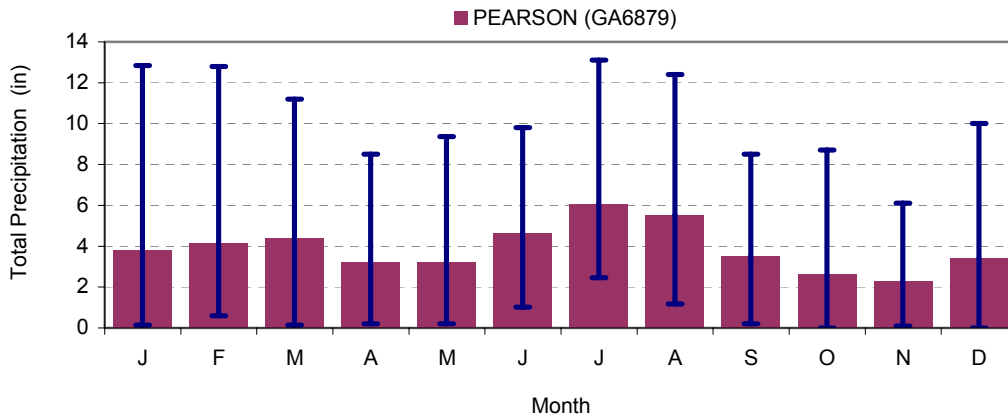

Monthly Precipitation (Median, Quartiles)

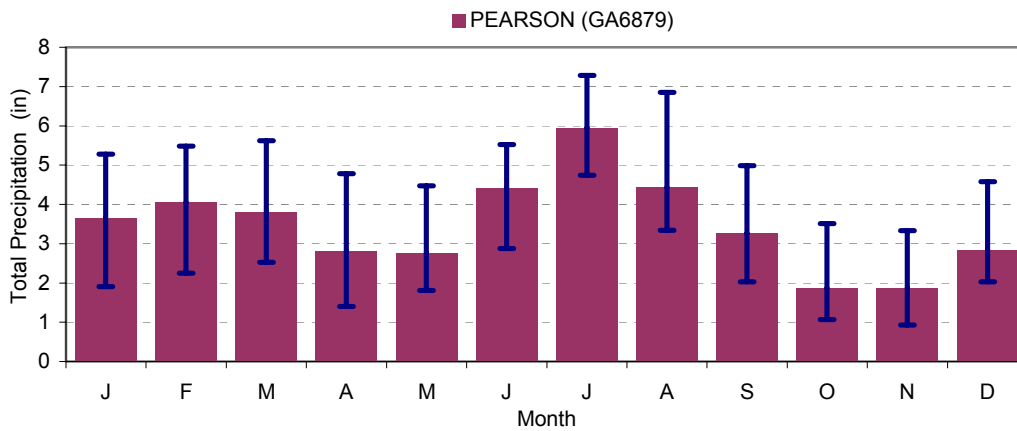

**Figure A-1. Average Monthly Mean Precipitation for Pearson (GA6879).**